WEXFORD COUNTY ROAD COMMISSION

OUR MISSION IS TO IMPROVE AND MAINTAIN A SAFE AND EFFICIENT ROAD SYSTEM

May 11, 2026

NOTICE TO CONTRACTORS AND MATERIAL SUPPLIERS

Sealed bids will be received at the office of the Wexford County Road Commission, 85 West Highway M-115, Boon, Michigan 49618 until 2:00 p.m. Tuesday, May 26, 2026, at which time and place the bids will be opened and read by the Wexford County Road Commission for culvert replacement.

US-131 and M-115 Southbound Ramp Culvert Replacement

Replace existing culvert with 72' of 36" diameter class A concrete pipe- approximately 380' south of M-115 on the US-131 southbound ramp, Wexford County. The work must be completed by August 13, 2026 prior to MDOT project 204028 commencing.

Specifications are available at the Road Commission office in Boon, Michigan. Telephone or faxed bids will not be accepted.

All materials and all work will be in accordance with the 2020 MDOT Standard Specifications for Construction and the attached special provisions.

Insurance requirements shall be in accordance with the 2020 MDOT Standard Specifications for Construction. Award is contingent upon Board approval.

The Wexford County Road Commission, in accordance with Title VI of the Civil Rights Act of 1964, 78 Stat. 252, 42 U.S.C 2000d to 2000d-4 and Title 49, Code of Federal Regulations, Department of Transportation, Sub-Title A, Office the Secretary, Part 21, Nondiscrimination in Federally assisted programs of the Department of Transportation issued pursuant to such Act, hereby notifies all bidders that it will affirmatively insure that in any contract entered into pursuant to this advertisement, minority business enterprises will be afforded full opportunity to submit bids in response to this invitation and will not be discriminated against on the grounds of race, color, or national origin in consideration for an award.

The Board reserves the right to reject any or all bids or any part of the same, to waive irregularities and/or informalities and to make the award in part or entirety in any manner deemed to be in the best interest of the Wexford County Road Commission.

Wexford County Road Commission

Harry Hagstrom, Chairman
Harold Falan, Vice-Chairman
Dean Jurik, Member
Jim Leggett, Member
Robert Hilty, Member

**WEXFORD COUNTY ROAD COMMISSION / MDOT TWA
 US-131 and M-115 Southbound Ramp Culvert Replacement
 Bid Tab**

Wexford County, Michigan.

All of the work herein specified will be paid for and included in the following pay items:

Item #	Pay Item	Unit	Estimated Quantity	Bid Unit Cost	Bid Item Total
1100001	Mobilization, Max	LSUM	1	\$	\$
2030002	Culv, Rem, 24 inch to 48 inch	Ea	1	\$	\$
3010002	Subbase, CIP	Cyd	170	\$	\$
3020030	Aggregate Base, 12 inch	Syd	170	\$	\$
4010053	Culv, End Sect, Conc, 36 inch	Ea	2	\$	\$
4010170	Culv, Cl A, Conc, 36 inch	Ft	72	\$	\$
5010005	HMA Surface, Rem	Syd	51	\$	\$
8120012	Barricade, Type III< High Intensity, Double Sided, Lighted, Furn	Ea	7	\$	\$
8120013	Barricade, Type III< High Intensity, Double Sided, Lighted, Oper	Ea	7	\$	\$
8120170	Minor Traf Devices	LSUM	1	\$	\$
8120252	Plastic Drum, Fluorescent, Furn	Ea	40	\$	\$
8120253	Plastic Drum, Fluorescent, Oper	Ea	40	\$	\$
8120310	Sign Cover	Ea	4	\$	\$
8120332	Sign, Portable, Changeable Message, NTCIP-Compliant, Furn	Ea	2	\$	\$
8120333	Sign, Portable, Changeable Message, NTCIP-Compliant, Oper	Ea	2	\$	\$
8120350	Sign, Type B, Temp, Prismatic, Furn	Sft	336	\$	\$
8120351	Sign, Type B, Temp, Prismatic, Oper	Sft	336	\$	\$
8162018	Slope Restoration, Freeway, Type F	Syd	40	\$	\$
				BID TOTAL =	\$

Company Name _____

Address _____

Email _____

By (Name and Title) _____

Authorized Signature _____

Date _____

MICHIGAN DEPARTMENT OF TRANSPORTATION

ROUTE: US-131
CLAM LAKE TOWNSHIP
WEXFORD COUNTY



WEXFORD COUNTY

COUNTY KEY

<u>SECTION</u>	<u>CONTROL SEC</u>	<u>JOB NO.</u>	<u>FED AID PROJ</u>
1	83031		NO

THESE PLANS REPRESENT TECHNICAL CONTENT. IF YOU REQUIRE ASSISTANCE ACCESSING THIS INFORMATION OR REQUIRE IT IN AN ALTERNATIVE FORMAT, CONTACT THE MICHIGAN DEPARTMENT OF TRANSPORTATION AMERICANS WITH DISABILITIES ACT (ADA) COORDINATOR AT WWW.MICHIGAN.GOV/MDOT-ADA

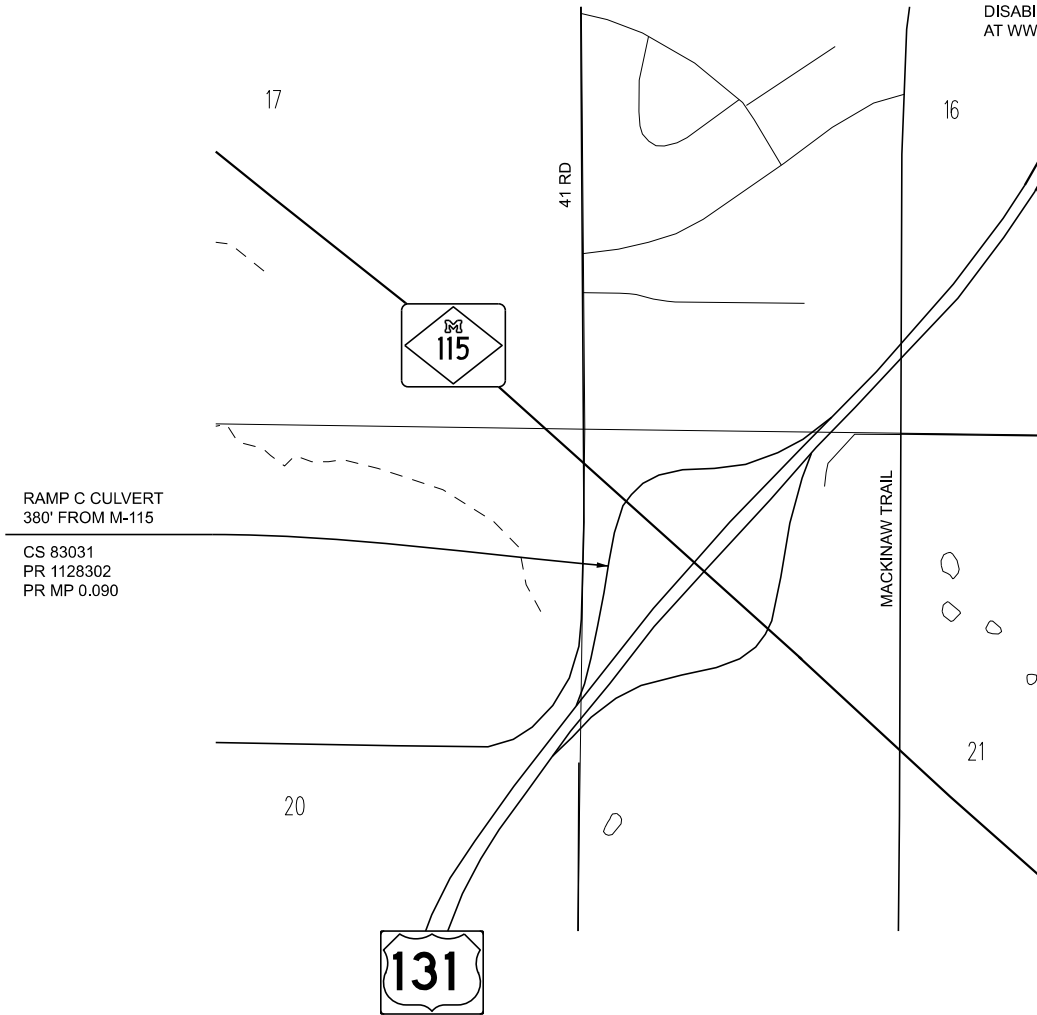

THE IMPROVEMENTS COVERED BY THESE PLANS SHALL BE DONE IN ACCORDANCE WITH THE MICHIGAN DEPARTMENT OF TRANSPORTATION 2020 STANDARD SPECIFICATIONS FOR CONSTRUCTION. PHYSICAL ROAD NUMBER (PR#) & MILEPOST (MP) DATA ARE FROM MICHIGAN GEOGRAPHIC FRAMEWORK VERSION # 25.

MILES: 0.1
CONTRACT FOR:
CULVERT REPLACEMENT

BRADLEY C. WIEFERICH, P.E. - DIRECTOR

	<p>NO SCALE</p>	DESIGN UNIT: PORATH	TSC: TRAVERSE CITY	DATE: 4/28/26	
		CS: 83031	TITLE SHEET		DRAWING SHEET
		JN:	US-131		US-131 TITLE SHEET 001

LOG OF PROJECT

PROJECT LOCATION

US-131 Southbound Ramp C approximately 380' south of M-115, Wexford County. See title sheet for more detail.

PROJECT DESCRIPTION

This project includes removing approximately 72 feet of 24-inch corrugated metal pipe with concrete end sections and replacing it with 72 feet of 36-inch concrete class A pipe.

ITEMS OF WORK

US-131 Ramp C Culvert Replacement: Remove existing pavement, excavate existing materials, remove existing 24" culvert, and place 72 ft of 36" class A concrete pipe. Place sub surface materials and aggregate as specified in the plans and in accordance with the 2020 Standard Specifications for Construction. There is no HMA paving in this project; the aggregate base will serve as the surface until paved with project 204028. For that reason, this work must be completed by August 13, 2026 prior to that project commencing. Project quantities are listed below:

Culv, Rem, 24 inch to 48 inch	1	Ea
HMA Surface, Rem	51	Syd
Culv, CI A, Conc, 36 inch	72	Ft
Culv End Sect, Conc, 36 inch	2	Ea
Subbase, CIP	170	Cyd
Aggregate Base, 12 inch	170	Syd
Slope Restoration, Freeway, Type F	40	Syd

MAINTAINING TRAFFIC ITEMS

Traffic will be maintained in accordance with the 2020 Standard Specifications for Construction, including any supplemental specifications, and as herein specified. All traffic control devices and their usage shall comply with the 2011 edition of the Michigan Manual of Uniform Traffic Control Devices (MMUTCD).

The maintenance of traffic will be according to the plans in this document. Project quantities are listed below:

Barricade, Type III, High Intensity, Double Sided, Lighted, Furn	7	Ea
Barricade, Type III, High Intensity, Double Sided, Lighted, Oper	7	Ea
Plastic Drum, Fluorescent, Furn	40	Ea
Plastic Drum, Fluorescent, Oper	40	Ea
Sign Cover	4	Ea
Sign, Portable, Changeable Message, NTCIP-Compliant, Furn	2	Ea
Sign, Portable, Changeable Message, NTCIP-Compliant, Oper	2	Ea
Sign Type B, Temp, Prismatic, Furn	336	Sft
Sign Type B, Temp, Prismatic, Oper	336	Sft

ENTIRE PROJECT QUANTITIES

The following quantities are estimated for use where needed throughout the project as directed by the Engineer.

Mobilization, Max	1	LSUM
Minor Traf Devices	1	LSUM

GENERAL NOTES

UTILITIES

MISS DIG/UNDERGROUND UTILITY NOTIFICATION

Contact MISS DIG System, Inc. for the protection of underground utilities and in conformance with MCL 460.721 et seq, by phone at 811 or 800-482-7171 or via the web at <http://www.missdig811.org/>, a minimum of 3 working days prior to excavating, excluding weekends and holidays.

BASES

AGGREGATE BASE

Use aggregate 21AA, for aggregate bases unless otherwise specified.

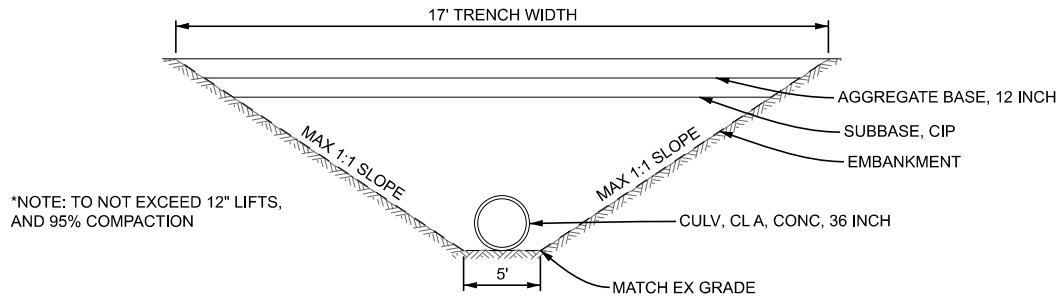
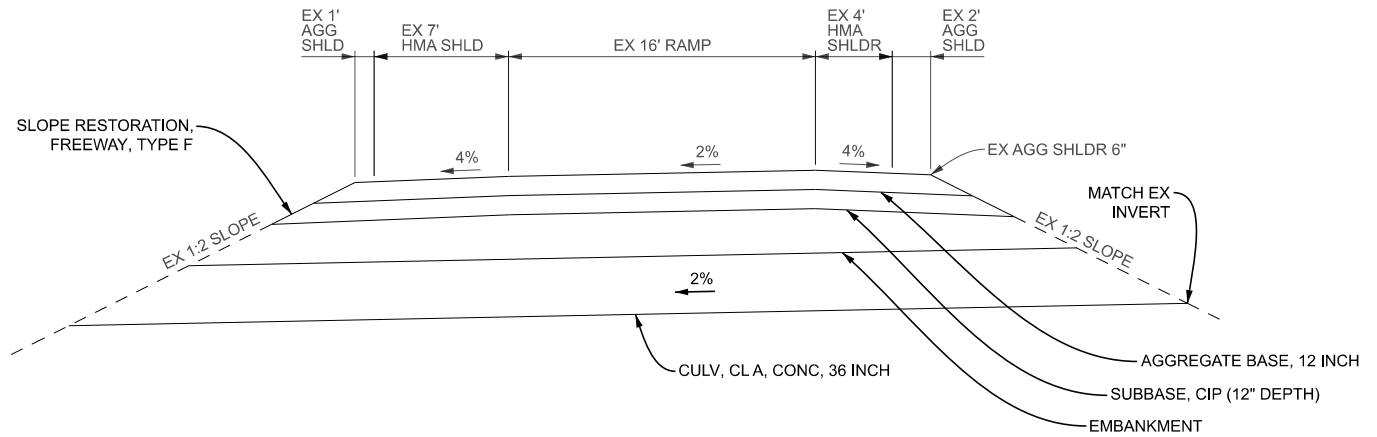
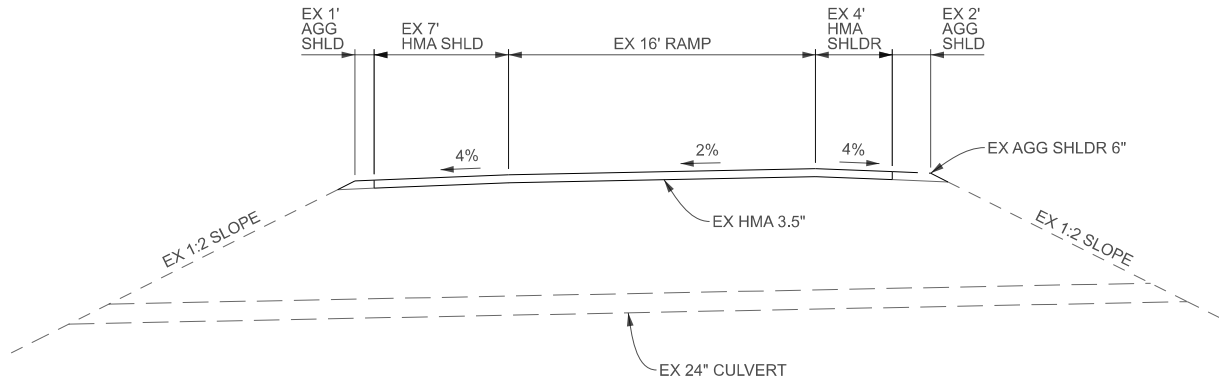

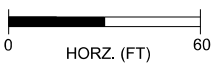

FILE: Ramp C Culvert.dgn

DESIGN UNIT: PORATH

CS: 83031

JN:

TSC: TRAVERSE CITY

RAMP C CULVERT REPLACEMENT

DATE: 4/21/26

DRAWING SHEET

SECT 1

MICHIGAN
DEPARTMENT OF TRANSPORTATION

SPECIAL PROVISION
FOR
MAINTAINING TRAFFIC

TRV:JLC

1 of 5

APPR:TRV:JPJ:05/01/2026

a. Description. This special provision consists of requirements and restrictions to maintain traffic on the southbound US-131 on ramp from M-115 (Ramp C) in Clam Lake Township, Wexford County.

b. General. Maintain traffic throughout the project in accordance with the standard specifications, typicals, and supplemental specifications in the contract and as described on the plans for this project.

c. Construction Influence Area (CIA). The CIA includes the right-of-way of the following roadways, within the approximate limits described below:

1. The entirety of the southbound US-131 on ramp from M-115 (Ramp C).
2. On southbound US-131 from Ramp C to approximately 1 mile south of Ramp C.
3. On M-115 from approximately 1 mile east to 1 mile west of Ramp C.

4. In addition, the CIA includes the right-of-way of any designated detour route or alternate route, intersecting roads and ramps adjacent to the work zone for a distance of approximately 1/4 mile in advance of the work zone or as far as the construction or detour signing extends.

d. Traffic Restrictions. Maintain traffic in accordance with the Maintaining Traffic Typicals contained herein, except as noted below. Changes or adjustments to the Maintaining Traffic Typicals may be necessary to fit field conditions, subject to approval of the Engineer or as determined by the Engineer.

1. Utilize the following Maintaining Traffic Typicals:
 - A. 100-GEN-KEY
 - B. 101-GEN-SPACING-CHARTS
 - C. 102-GEN-NOTES
 - D. 103-GEN-SIGN
 - E. 104-GEN-AB
 - F. 107-GEN-SPEED

G. 122-NFW-SHL-(R)

H. 200-FW-SHL-(R)

I. 220-FW-EnR-C

J. WZD-100-A

K. WZD-125-E

2. Do not work, deliver material, or close lanes on Saturday, Sunday, or during the holiday periods as defined in Table 1, unless approved by the Engineer.

Table 1: 2026 Holiday Periods

Holiday	Start Date and Time	End Date and Time
Memorial Day	3:00pm, Friday, May 22nd	6:00am, Tuesday, May 26th
Independence Day	3:00pm, Thursday, July 2nd	6:00am, Monday, July 6th
Labor Day	3:00pm, Friday, September 4th	6:00am, Tuesday, September 8th

3. Perform work and lane closures between sunrise and sunset, local time, unless otherwise approved by the Engineer.

4. Close any dedicated lanes (exit, ramp, turn, etc.) prior to the location under construction.

5. When a lane is closed, place channelizing devices at cross streets and major drives to form a radius that clearly defines the approaches to the through and turning traffic.

6. Close the ramps below during a time frame that does not conflict with holidays or special events.

A. The following ramp can be closed for up to 1 calendar day.

(1) M-115 Southbound US-131 on ramp (Ramp C).

e. Traffic General.

1. For any lane open to traffic, provide a minimum lane width of 11 feet with 2 feet of shy distance on both sides unless identified otherwise on plans.

2. Do not close lanes where work can be accomplished with a shoulder closure. Do not occupy any part of the active traffic lane with personnel or equipment when utilizing a shoulder closure. Place lane closures only in areas as shown on the plans unless otherwise directed by the Engineer.

3. Prior to shifting traffic onto shoulders or opening any lanes/shoulders and/or ramps, remove, by sweeping all accumulated debris that has collected within the shoulder and/or within the closed lane/shoulder.

4. A speed reduction will not be used.

5. Develop and submit to the Engineer an Internal Traffic Control Plan (ITCP) per subsection 104.11.B of the Standard Specifications for Construction. The requirements listed herein are the requirements for a Type A ITCP. Submit the Type A ITCP at the preconstruction meeting. The Engineer will have 7 calendar days to review the ITCP for approval or provide comments for revisions required to obtain approval. Include in the ITCP, at a minimum, the proposed ingress/egress locations for construction equipment and vehicles, traffic control devices that will be utilized to warn the motoring public of ingress/egress locations, and measures that will be taken to ensure compliance with the ITCP. Ensure that the ITCP minimizes conflicts between construction vehicles and motorists and maintains overall safety and mobility within the work zone. No work may begin prior to approval of the ITCP. Additional time required to obtain an approved ITCP will not be cause for delay or impact claims. All costs associated with obtaining an approved ITCP, providing and executing all parts of the approved ITCP including required traffic control devices, or resolving an incomplete or unacceptable ITCP will be borne by the Contractor.

6. Protect the work area at the end of each day. Close all open access points on the project to traffic with devices approved by the Engineer.

7. The Engineer will be responsible for notifying emergency services, transit agencies, law enforcement and schools prior to any lane closures, detours or major traffic shifts. In addition, the Contractor will be responsible for working with and complying with any coordination that is necessary with the Department and emergency services, transit agencies, law enforcement and schools. All costs associated with these coordination efforts will be considered included in the pay item "Minor Traf Devices".

8. Obtain all necessary permits from local governments within areas of local jurisdiction, including noise/dust ordinance waivers when required, prior to placing construction signing on local roads.

A. The Department will reimburse permit costs in accordance with subsection 107.02.A of the Standard Specification for Construction. Adhere to all requirements made by local maintaining agencies regarding placement of traffic control devices prior to closing lanes on roadways not under MDOT jurisdiction.

9. Remove all temporary traffic control devices from MDOT right-of-way during any shut down periods unless needed for directly maintaining or channelizing traffic. No additional payment will be made for removal and/or redeployment of these devices except for in the case of an approved extension of time.

10. Once work is initiated that includes any lane restrictions, that work must be continued daily until completed. A lack of work activity for more than 1 day will require the removal of lane closures at no expense to the Department.

f. Earthwork and Excavation.

1. Delineate excavated areas located within 3 feet of traffic with channelizing devices at 20 feet spacing along the excavated area, and 100 feet before the area, or as shown on the maintaining traffic plans.

2. Use protective fencing to protect open excavations within the work zone during non-working hours.

g. Traffic Control Devices. Ensure all traffic control devices are in accordance with the *MMUTCD* and must meet the “acceptable” criteria as defined in the *ATSSA* publication entitled “*Quality Guidelines for Temporary Traffic Control Devices and Features*” at the time of initial deployment and after each major stage change.

1. During non-working periods, place applicable advance signs and channelizing devices at specific locations, as directed by the Engineer, at no additional cost to the Department.

2. Notify the Engineer 24 hours in advance of when traffic control devices are being delivered to the project site, to allow for initial inspection of devices to take place.

3. Remove from the project site all traffic control devices (including detour signing) no longer needed for a particular operation and equipment for construction within 5 work days of reopening the shoulder/lane/roadway.

4. Channelizing Devices.

A. Ensure all devices have sufficient ballast to prevent moving or tipping. If moving or tipping occurs, place additional ballast, as directed by the Engineer, at no additional cost to the Department. No more than two ballasts are allowed on each channelizing device.

B. Do not use caution tape on channelizing devices for traffic control and/or pedestrian traffic control on this project.

5. Temporary Signs.

A. Additional W20-1 (ROAD WORK AHEAD) signs are included in the quantities to be placed on all intersecting or adjacent roads where construction activities may be encountered.

B. Fabricate, install, and remove temporary sign overlays on existing signs with the pay item for Sign, Type B, Temp, Prismatic, Furn. Attach the overlay in accordance with subsection 812.03.D.2 of the Standard Specifications for Construction.

6. Portable Changeable Message Signs (PCMS's). Use PCMS's to warn traffic of upcoming and changing traffic control during the life of the project. Obtain approval from the Engineer for all sign locations.

A. Install PCMS's and make them operational a minimum of 7 calendar days prior to the start of work, unless otherwise directed by the Engineer. Messages displayed on the PCMS's must conform to MDOT's policy on PCMS's. Notify the Engineer if displaying a different message than those listed below for the project.

B. Do not leave PCMS's with a blank screen within the clear zone of any roadway at any time. Remove the PCMS or display flashing dots in each corner of the screen when there is no message to display. Update the PCMS messages at the end of each work period to reflect current traffic lane restrictions.

C. Display the following two messages greater than 6 days prior to work.

US-131 SOUTH ON RAMP	TO BE CLOSED [DATE]
----------------------------	---------------------------

D. Display the following two messages within 6 days prior to work.

US-131 SOUTH ON RAMP	TO BE CLOSED [DAY]
----------------------------	--------------------------

E. Display the following two messages during work.

US-131 S ON RAMP CLOSED	FOLLOW US-131 N TO EX177
-------------------------------	--------------------------------

h. Temporary Pavement Markings.

1. Replace all existing pavement markings that are removed for traffic control or obliterated during construction.
2. Delineate the edge line using drums.

i. Measurement and Payment. Payment will be in accordance with the standard specifications unless otherwise specified. No additional payment will be made for the following activities:

1. Transporting traffic control items from site to site.
2. Providing sufficient vehicles and staff to make changes as-needed on site during work.
3. Providing sufficient vehicles and staff to remove closures from the roadway.

TYPICAL NUMBER KEY

CODES

AB = ARROW BOARD AW = ADVANCE WARNING C = CLOSURE CLT = CENTER LEFT TURN LANE CROSS = CROSSOVER CruSha = CRUSH AND SHAPE EM = EARLY MERGE EnR = ENTRANCE RAMP ExR = EXIT RAMP FW = FREEWAY GEN = GENERAL INFORMATION GORE = FREEWAY GORE AREA IN = INSIDE INT = INTERSECTION L = LANE (L) = LEFT LC = LANE CLOSURE LD = LONG DURATION	LO = LANE OPEN O = OUTSIDE (LANE CLOSURE) OUT = OUTSIDE OF SHOULDER MID = MIDDLE OF INTERSECTION OR ROAD NFW = NON-FREEWAY PARK = PARKING LANE PCMS = PORTABLE CHANGEABLE MESSAGE SIGN (R) = RIGHT ROLL = ROLLING ROADBLOCK RUM = RUMBLE STRIP SD = SHORT DURATION SHL = SHOULDER CLOSURE SIGN = SIGN SP = SPECIAL SPEED = SPEED STA = STOPPED TRAFFIC ADVISORY TR = TRAFFIC REGULATOR TS = TEMPORARY SIGNAL ZIP = ZIPPER MERGE
--	---

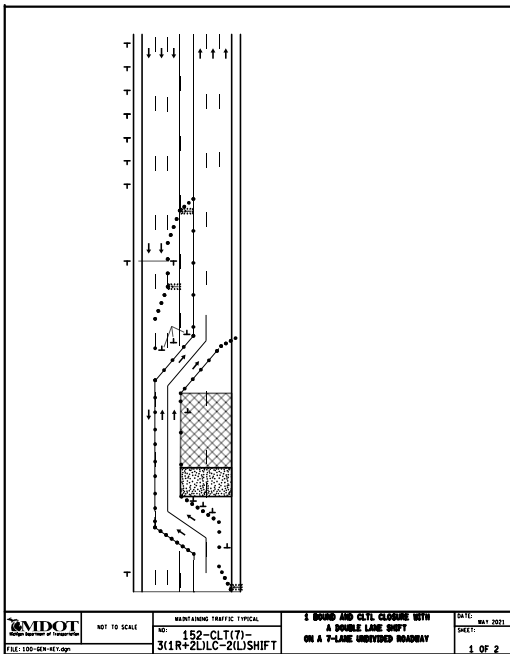

- 100 - GENERAL NOTES
- 110 - TRAFFIC REGULATORS
- 120 - NON-FREEWAY
- 130 - CENTER LEFT TURN (CLT) LANES
- 140 - PARKING LANES
- 150 - CLT 7 LANE SECTIONS
- 160 - SIGNAL WORK
- 200 - FREEWAY CLOSURES
- 210 - FREEWAY LANE SHIFTS
- 220 - FREEWAY ENTRANCE RAMPS
- 230 - FREEWAY EXIT RAMPS
- 300 - ADVANCE WARNINGS
- 310 - CROSSOVER CLOSURE
- 320 - CRUSH AND SHAPE
- 340 - MERGE SYSTEMS
- 350 - GORE LOCATIONS
- 360 - ROLLING ROADBLOCK
- 4000 - MAINTENANCE
- 5000 - SURVEY

EXAMPLE TYPICAL

CODE: 152-CTL(7)-3(1R+2L)LC-2(L)SHIFT

152 - TYPICAL NUMBER

CTL(7) = CENTER LEFT TURN LANE, 7 LANES TOTAL.

3(1R+2L)LC = 3 LANES CLOSED, (1 RIGHT LANE AND 2 LEFT LANES).

2(L)SHIFT = 2 LANES SHIFTED TO THE LEFT.

NOT TO SCALE

	NOT TO SCALE	MAINTAINING TRAFFIC TYPICAL	TYPICAL NUMBERING KEY	DATE: DECEMBER 2021
		NO: 100-GEN-KEY		SHEET: 1 OF 1

FILE: 100-GEN-KEY.dgn

DISTANCE BETWEEN TRAFFIC SIGNS, "D"

"D" DISTANCES	POSTED SPEED LIMIT, MPH (PRIOR TO WORK AREA)										
	25	30	35	40	45	50	55	60	65	70	75
D (FEET)	250	300	350	400	450	500	550	600	650	700	750

GUIDELINES FOR LENGTH OF LONGITUDINAL BUFFER SPACE, "B"

"B" LENGTHS	SPEED*, MPH (PRIOR TO WORK AREA)											
	20	25	30	35	40	45	50	55	60	65	70	75
B (FEET)	33	50	83	132	181	230	279	329	411	476	542	625

* POSTED SPEED, OFF-PEAK 85TH PERCENTILE SPEED PRIOR TO WORK STARTING, OR THE ANTICIPATED OPERATING SPEED.

MINIMUM MERGING TAPER LENGTH, "L" (FEET)

OFFSET (FEET)	POSTED SPEED LIMIT, MPH (PRIOR TO WORK AREA)										
	25	30	35	40	45	50	55	60	65	70	75
1	11	15	21	27	45	50	55	60	65	70	75
2	21	30	41	54	90	100	110	120	130	140	150
3	32	45	62	80	135	150	165	180	195	210	225
4	42	60	82	107	180	200	220	240	260	280	300
5	53	75	103	134	225	250	275	300	325	350	375
6	63	90	123	160	270	300	330	360	390	420	450
7	73	105	143	187	315	350	385	420	455	490	525
8	84	120	164	214	360	400	440	480	520	560	600
9	94	135	184	240	405	450	495	540	585	630	675
10	105	150	205	267	450	500	550	600	650	700	750
11	115	165	225	294	495	550	605	660	715	770	825
12	125	180	245	320	540	600	660	720	780	840	900
13	136	195	266	347	585	650	715	780	845	910	975
14	146	210	286	374	630	700	770	840	910	980	1050
15	157	225	307	400	675	750	825	900	975	1050	1125

NOT TO SCALE

	NOT TO SCALE	MAINTAINING TRAFFIC TYPICAL	"B", "D" AND "L" TABLES CHANNELIZING DEVICE SPACING, SIGN BORDER KEY, AND ROLL-AHEAD SPACING	DATE: MAY 2021
		NO: 101-GEN-SPACING-CHARTS		SHEET: 1 OF 3

THE FORMULAS FOR THE MINIMUM LENGTH OF A MERGING TAPER IN DERIVING THE "L" VALUES SHOWN IN THE ABOVE TABLES ARE AS FOLLOWS:

"L" = $\frac{W \times S^2}{60}$ WHERE POSTED SPEED PRIOR TO THE WORK AREA IS 40 MPH OR LESS

"L" = W X S WHERE POSTED SPEED PRIOR TO THE WORK AREA IS 45 MPH OR GREATER

L = MINIMUM LENGTH OF MERGING TAPER
 S = POSTED SPEED LIMIT IN MPH PRIOR TO WORK AREA
 W = WIDTH OF OFFSET

TYPES OF TAPERS

UPSTREAM TAPERS

- MERGING TAPER
- SHIFTING TAPER
- SHOULDER TAPER
- 2 TO 1 LANE ROAD TAPER

TAPER LENGTH

- L - MINIMUM
- 1/2 L - MINIMUM
- 1/3 L - MINIMUM
- 100' - MAXIMUM

DOWNSTREAM TAPERS
 (USE IS RECOMMENDED)

100' (PER LANE)

MAXIMUM SPACING FOR CHANNELIZING DEVICES

WORK ZONE SPEED LIMIT	DRUM AND 42" DEVICE SPACING (FT)		NIGHTTIME 42" DEVICE SPACING (FT)	
	TAPER	TANGENT	TAPER	TANGENT
< 45 MPH	1 x SPEED LIMIT	2 x SPEED LIMIT	25 FEET	50 FEET
≥ 45 MPH	50 FEET	100 FEET	25 FEET	50 FEET

SIGN OUTLINE KEY

DASHED OUTLINES INDICATE A SIGN THAT EXISTS ON SITE, AND NEEDS TO BE COVERED.

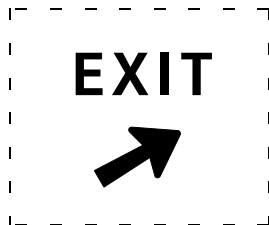

SOLID OUTLINES INDICATE A SIGN THAT IS TO BE PLACED ON THE PROJECT



NOT TO SCALE

	NOT TO SCALE	MAINTAINING TRAFFIC TYPICAL	"B", "D" AND "L" TABLES CHANNELIZING DEVICE SPACING SIGN BORDER KEY AND ROLL-AHEAD SPACING	DATE: MAY 2021
		NO: 101-GEN-SPACING-CHARTS		SHEET: 2 OF 3

GUIDELINES FOR ROLL-AHEAD DISTANCES FOR TMA VEHICLES – TEST LEVEL 2

WEIGHT OF TMA VEHICLE	PREVAILING SPEED (POSTED SPEED PRIOR TO WORK ZONE)	ROLL-AHEAD DISTANCE* (DISTANCE FROM FRONT OF TMA VEHICLE TO WORK AREA)
5.5 TONS (STATIONARY)	40 MPH OR LESS	25 FT

* ROLL-AHEAD DISTANCES ARE CALCULATED USING A 4,410 POUND IMPACT VEHICLE WEIGHT.

GUIDELINES FOR ROLL-AHEAD DISTANCES FOR TMA VEHICLES – TEST LEVEL 3

WEIGHT OF TMA VEHICLE	PREVAILING SPEED (POSTED SPEED PRIOR TO WORK ZONE)	ROLL-AHEAD DISTANCE* (DISTANCE FROM FRONT OF TMA VEHICLE TO WORK AREA)
5 TONS (MOBILE)	45 MPH	100 FT
	50-55 MPH	150 FT
	60-75 MPH	175 FT
12 TONS (STATIONARY)	45 MPH	25 FT
	50-55 MPH	25 FT
	60-75 MPH	50 FT

* ROLL-AHEAD DISTANCES ARE CALCULATED USING A 10,000 POUND IMPACT VEHICLE WEIGHT.



NOT TO SCALE

MAINTAINING TRAFFIC TYPICAL

NO: 101-GEN-SPACING-CHARTS

"B", "D" AND "L" TABLES
CHANNELIZING DEVICE SPACING
SIGN BORDER KEY AND ROLL AHEAD SPACING

DATE: MAY 2021

SHEET: 3 OF 3

THE FOLLOWING NOTES APPLY IF CALLED FOR ON THE TRAFFIC TYPICAL

GENERAL NOTES

- G1: SEE GEN-SPACING-CHARTS FOR COMMON VALUES INCLUDING:
 D = DISTANCE BETWEEN TRAFFIC CONTROL DEVICES
 L = MINIMUM LENGTH OF TAPER
 B = LENGTH OF LONGITUDINAL BUFFER
 ROLL AHEAD DISTANCE
- G2: DISTANCE BETWEEN SIGNS, "D", THE VALUES FOR WHICH ARE SHOWN IN TYPICAL GEN-KEY ARE APPROXIMATE AND MAY NEED ADJUSTING AS DIRECTED BY THE ENGINEER.
- G3: ALL TEMPORARY SIGNS, TYPE III BARRICADES, THEIR SUPPORT SYSTEMS AND LIGHTING MUST MEET NATIONAL COOPERATIVE HIGHWAY RESEARCH PROGRAM REPORT 350 (NCHRP 350) TEST LEVEL 3, OR MANUAL FOR ASSESSING SAFETY HARDWARE (MASH) TL-3 AS WELL AS THE CURRENT EDITION OF THE MICHIGAN MANUAL ON UNIFORM TRAFFIC CONTROL DEVICES, THE CURRENT EDITION OF THE STANDARD SPECIFICATIONS FOR CONSTRUCTION, THE STANDARD PLANS AND APPLICABLE SPECIAL PROVISIONS. ONLY DESIGNS AND MATERIALS APPROVED BY MDTOT WILL BE ALLOWED.
- G4: DO NOT STORE EQUIPMENT, MATERIALS OR PERFORM WORK IN ESTABLISHED BUFFER AREAS.
- G5: ALL EXISTING PAVEMENT MARKINGS WHICH ARE IN CONFLICT WITH EITHER PROPOSED CHANGES IN TRAFFIC PATTERNS OR PROPOSED TEMPORARY TRAFFIC MARKINGS SHALL BE REMOVED BEFORE ANY CHANGE IS MADE IN THE TRAFFIC PATTERN. EXCEPTION WILL BE MADE FOR TRAFFIC PATTERNS FOR WORK LESS THAN THREE DAYS THAT ARE ADEQUATELY DELINEATED BY OTHER TRAFFIC CONTROL DEVICES.

SIGN NOTES

- S1: ALL NON-APPLICABLE SIGNING WITHIN THE CIA MUST BE MODIFIED TO FIT CONDITIONS, COVERED, OR REMOVED. FOR GUIDANCE SEE THE WORK ZONE SAFETY AND MOBILITY MANUAL, SECTIONS 6.01.09 AND 6.01.10.
- S2: R5-18b SIGNS ARE ONLY REQUIRED ON FREEWAY PROJECTS WITH A DURATION OF 15 DAYS OR LONGER OR NON-FREEWAY PROJECTS WITH A DURATION OF 90 DAYS OR LONGER. TO APPLY THIS TYPICAL WITHOUT R5-18b SIGNS, REMOVE THE SIGNS AND CONSOLIDATE THE SEQUENCE AS APPROPRIATE.
- S3: R5-18c IS ONLY REQUIRED IN THE INITIAL SIGNING SEQUENCE IN THE WORK ZONE. OMIT THIS SIGN IN SUBSEQUENT SEQUENCES IN THE SAME WORK ZONE.
- S4: ADDITIONAL SIGNING AND/OR ELONGATED SIGNING SEQUENCES SHOULD BE USED WHEN TRAFFIC VOLUMES ARE SIGNIFICANT ENOUGH TO CREATE BACKUPS BEYOND THE W20-5 SIGNS.
- S5: PLACE ADDITIONAL SPEED LIMIT SIGNS REFLECTING THE WORK ZONE SPEED AFTER EACH MAJOR CROSSROAD THAT INTERSECTS THE WORK ZONE, OR AFTER EACH ENTRANCE RAMP THAT COMES ONTO THE FREEWAY WHERE THE REDUCED SPEED IS IN EFFECT. PLACE ADDITIONAL SPEED LIMIT SIGNS AT INTERVALS ALONG THE ROADWAY SUCH THAT NO SPEED LIMIT SIGNS ARE MORE THAN 2 MILES APART. WHEN REDUCED SPEED LIMITS ARE UTILIZED IN THE WORK AREA, PLACE ADDITIONAL SPEED LIMIT SIGNS RETURNING TRAFFIC TO ITS NORMAL SPEED BEYOND THE LIMITS OF THE WORK AREA AS INDICATED. IF PERMANENT SIGNS DISPLAYING THE CORRECT SPEED LIMIT ARE POSTED, OMIT ALL W3-5b AND R2-1 SIGNS AND REDUCE SPACING ACCORDINGLY.
- S6: FABRICATE SPECIAL SIGNS IN ACCORDANCE WITH CURRENT SIGNING DESIGN STANDARDS.
- S7: PLACE ADDITIONAL R8-3 SIGNS AT A MAXIMUM 500' SPACING THROUGHOUT THE WORK ZONE.
- S8: WHEN SPEED LIMIT SIGNS CANNOT BE PLACED SIDE BY SIDE AS SHOWN, PLACE THEM "D" DISTANCE APART.
- S9: STOP SIGNS NOT REQUIRED IF SIGNALS ARE ON 4-WAY FLASHING RED. STOP AHEAD SIGNS ARE NOT REQUIRED IF THERE IS ADEQUATE VISIBILITY OF THE STOP SIGN OR IF SIGNALS ARE BEING USED TO CONTROL TRAFFIC.
- S10: PLACE REDUCED SPEED ZONE AHEAD SIGN (W3-5b) HERE WHEN USING A SPEED REDUCTION IN THIS DIRECTION.
- S11: THE NUMBER OF W1-6 SHIFT SIGNS TO PLACE FOR A SHIFT IS AS FOLLOWS:
 SHIFTS 4FT OR LESS, PLACE ONE W1-6(R)(L)
 SHIFTS 5FT TO 12FT, PLACE TWO W1-6(R)(L)
 SHIFTS MORE THAN 12FT, PLACE THREE OR MORE W1-6(R)(L) SIGNS DEPENDING UPON LENGTH OF SHIFT AND AS PER THE ENGINEER.
- S12: PLACE R2-1 SIGNS AS DETAILED IN NOTE S5 WHEN THERE IS A SPEED REDUCTION IN THIS DIRECTION

TRAFFIC REGULATOR NOTES

- TR1: TRAFFIC REGULATORS MUST FOLLOW ALL THE REQUIREMENTS IN THE STANDARD SPECIFICATIONS, THE STANDARD PLANS AND APPLICABLE SPECIAL PROVISIONS, THE CURRENT VERSIONS OF THE TRAFFIC REGULATOR'S INSTRUCTION MANUAL AND THE VIDEO "HOW TO SAFELY REGULATE TRAFFIC IN MICHIGAN". THE MAXIMUM DISTANCE BETWEEN THE TRAFFIC REGULATORS IS DETERMINED BY THE ROADWAY ADT, GEOMETRICS, AND AS DIRECTED BY THE ENGINEER.
- TR2: PROVIDE APPROPRIATE BALLOON LIGHTING TO SUFFICIENTLY ILLUMINATE TRAFFIC REGULATOR'S STATIONS WHEN TRAFFIC REGULATING IS ALLOWED DURING THE HOURS OF DARKNESS.

TEMPORARY TRAFFIC CONTROL DEVICE NOTES

- TC1: THE MAXIMUM DISTANCE IN FEET BETWEEN CHANNELIZING DEVICES IN A TAPER SHOULD NOT EXCEED 1.0 TIMES THE WORK ZONE SPEED LIMIT IN MPH FOR ROADWAYS WITH A POSTED WORK ZONE SPEED LIMIT LESS THAN 45 MPH AND SHOULD NOT EXCEED 50 FEET ON ROADWAYS WITH A POSTED WORK ZONE SPEED LIMIT OF 45 MPH OR GREATER. THE SPACING FOR 42 INCH CHANNELIZING DEVICE TAPERS ARE NOT TO EXCEED 25 FEET AT NIGHT.
- TC2: THE MAXIMUM DISTANCE IN FEET BETWEEN CHANNELIZING DEVICES IN A TANGENT SHOULD NOT EXCEED TWICE THE WORK ZONE SPEED LIMIT IN MPH FOR ROADWAYS WITH A POSTED WORK ZONE SPEED LIMIT LESS THAN 45 MPH AND SHOULD NOT EXCEED 100 FEET ON ROADWAYS WITH A POSTED WORK ZONE SPEED LIMIT OF 45 MPH OR GREATER. THE SPACING FOR 42 INCH CHANNELIZING DEVICE TANGENTS ARE NOT TO EXCEED 50 FEET AT NIGHT.
- TC3: TYPE III BARRICADES MUST BE LIGHTED FOR OVERNIGHT CLOSURES.
- TC4: WHEN THE HAUL ROAD IS NOT IN USE, PLACE LIGHTED TYPE III BARRICADES WITH "ROAD CLOSED" EXTENDING COMPLETELY ACROSS THE HAUL ROAD.
- TC5: USE OBJECT MARKER SIGNS IN LIEU OF THE TYPE B HIGH INTENSITY LIGHT SHOWN IN THE STANDARD PLAN FOR TEMPORARY CONCRETE BARRIER (R-53, AND R-126) WHEN USED WITH A TEMPORARY SIGNAL SYSTEM. THE OBJECT MARKERS MUST BE A MINIMUM OF 12 INCHES IN WIDTH AND 36 INCHES IN HEIGHT AND HAVE ORANGE AND WHITE RETROREFLECTIVE SHEETING. THE RETROREFLECTIVE SHEETING MUST HAVE ALTERNATING DIAGONAL ORANGE AND WHITE STRIPES SLOPING DOWNWARD AT AN ANGLE OF 45 DEGREES IN THE DIRECTION VEHICULAR TRAFFIC IS TO PASS.
- TC6: PLACE LIGHTED ARROW PANELS AS CLOSE TO THE BEGINNING OF TAPERS AS PRACTICAL, BUT NOT IN A MANNER THAT WILL OBSCURE OR CONFUSE APPROACHING MOTORISTS WHEN PHYSICAL LIMITATIONS RESTRICT PLACEMENT. IN CURBED SECTIONS, IF ARROW BOARD CANNOT BE PLACED BEHIND CURB, PLACE ARROW BOARD IN THE CLOSED LANE AS CLOSE TO THE BEGINNING OF TAPER AS POSSIBLE.
- TC7: ADDITIONAL TYPE III BARRICADES MAY BE REQUIRED TO COMPLETELY CLOSE OFF ROAD FROM EDGE OF PAVEMENT TO EDGE OF PAVEMENT.
- TC8: WHERE THE SHIFTED SECTION IS SHORTER THAN 600 FEET, A DOUBLE REVERSE CURVE SIGN (W24-1) CAN BE USED INSTEAD OF THE FIRST REVERSE CURVE SIGN, AND THE SECOND REVERSE CURVE SIGN CAN BE OMITTED.
- TC9: RUMBLE STRIPS ARE TO BE PLACED AS SPECIFIED IN THE CONTRACT. IF NOT SPECIFIED IN THE CONTRACT, PLACE RUMBLE STRIPS AS SHOWN, AND IN ACCORDANCE WITH THE RUMBLE STRIP MANUFACTURER'S RECOMMENDATIONS. AN ARRAY OF RUMBLE STRIPS CONTAINS THREE RUMBLE STRIPS. PLACE THE RUMBLE STRIPS IN THE ARRAY AT A CONSISTENT DISTANCE, BETWEEN 10' AND 20' APART.
- TC10: SEE THE WORK ZONE SAFETY AND MOBILITY MANUAL, PORTABLE CHANGEABLE MESSAGE SIGN GUIDELINES FOR RECOMMENDED AND CORRECT PCMS MESSAGING. STAGGER PCMS THAT ARE ON OPPOSING SIDES OF THE ROAD 1000 FEET FROM EACH OTHER.

RAMP NOTES

- RMP1: WHEN CONDITIONS ALLOW, E5-1 SIGNS MUST BE REMOVED OR COVERED AND CHANNELIZING DEVICES MUST BE POSITIONED TO ENABLE RAMP TRAFFIC TO DIVERGE IN A FREE MANNER
- RMP2: STOP AND YIELD CONDITIONS SHOULD BE AVOIDED WHENEVER PRACTICAL. WHEN CONDITIONS WARRANT, R1-1 SIGNS MAY BE USED IN PLACE OF R1-2 SIGNS. WHEN R-1 SIGNS ARE USED, W3-1 SIGNS MUST BE USED IN PLACE OF W3-2 SIGNS. CONSIDERATION SHOULD BE GIVEN TO CLOSING THE RAMP TO COMPLETE WORK TO ALLOW AN ADEQUATE MERGE DISTANCE. WORK SHOULD BE EXPEDITED TO AVOID THE STOP AND/OR YIELD CONDITIONS.

	NOT TO SCALE	MAINTAINING TRAFFIC TYPICAL	TRAFFIC TYPICALS NOTE SHEET	DATE: APRIL 2022
		NO: 102-GEN-NOTES		SHEET: 1 OF 2
FILE: 102-GEN-NOTES.dgn				

THE FOLLOWING NOTES APPLY IF CALLED FOR ON THE TRAFFIC TYPICAL

SIGNAL NOTES

- SIG1: EXISTING SIGNAL MUST BE EITHER 4-WAY FLASHING RED, BAGGED, OR TURNED OFF.
- SIG2: SIGNAL IS IN OPERATION.
- SIG3: DELINEATE THE WORK ZONE AREA WITH 28 INCH CONES FOR DAYTIME WORK, OR 42 INCH CHANNELIZING DEVICES FOR NIGHTTIME WORK.
- SIG4: THE CONTRACTOR MUST HAVE A DESIGNATED SPOTTER IF THE AERIAL BUCKET TRUCK IS LOCATED OVER ACTIVE TRAVEL LANES.
- SIG5: THE LOWEST POINT OF THE BUCKET MAY NOT TRAVEL BELOW 14 FOOT VERTICAL CLEARANCE. THE CONTRACTOR MUST UTILIZE AN ALTERNATE SET UP, OR PLACE THE INTERSECTION IN A 4 WAY STOP IF THE 14 FOOT VERTICAL CLEARANCE IS COMPROMIZED. USE TRAFFIC REGULATORS TO CONTROL TRAFFIC THROUGH THE INTERSECTION WHEN TRAFFIC IS PLACED IN A 4 WAY STOP.
- SIG6: DELINEATE THE TRUCK WITH CHANNELIZING DEVICES. THE POSITION OF THE TRUCK MAY BE MOVED TO FACILITATE WORK.

MAINTENANCE AND SURVEYING NOTES

- MS1: WHENEVER STOPPING SIGHT DISTANCE EXISTS TO THE REAR, THE SHADOW VEHICLES SHOULD MAINTAIN THE RECOMENDED DISTANCE FROM THE WORK AREA AND PROCEED AT THE SAME SPEED. THE SHADOW VEHICLE SHOULD SLOW DOWN AND TRAVEL AT A FARTHER DISTANCE TO PROVIDE ADEQUATE SIGHT DISTANCE IN ADVANCE OF VERTICAL OR HORIZONTAL CURVES.
- MS2: WORKERS OUTSIDE OF VEHICLES SHOULD WORK WITHIN 150' OF WORK VEHICLES WITH AN ACTIVATED BEACON, BETWEEN THE "BEGIN WORK CONVOY" SIGN AND THE "END WORK CONVOY" SIGN, OR BETWEEN THE "WORK ZONE BEGINS" AND "END ROAD WORK" SIGN.
- MS3: WORK OR SHADOW VEHICLES WITH OR WITHOUT A TMA MAY BE USED TO SEPARATE THE WORK SPACE FROM TRAFFIC. IF USED, THE VEHICLES SHOULD BE PARKED ACCORDING TO THE ROLL AHEAD DISTANCE TABLES.
- MS4: WORK AND SHADOW VEHICLES SHALL BE APPROPRIATELY EQUIPPED WITH AN ACTIVATED AMBER BEACON.
- MS5: WHEN WORKERS ARE OUTSIDE THEIR VEHICLES IN AN EXISTING LANE WHILE A MOBILE OPERATION IS OCCURRING DURING THE NIGHTTIME HOURS, CHANNELIZING DEVICES TO DELINEATE OPEN OR CLOSED LANES AT 50 FT SPACING MUST BE USED. AN EXAMPLE OF AN OPERATION (BUT NOT LIMITED TO) IS THE LAYOUT OF CONCRETE PATCHES.
- MS6: W21-6 AND W20-1 SIGNS MAY BE SUBSTITUTED AS DETERMINED BY THE TYPE OF WORK TAKING PLACE AS PER THE ENGINEER.



NOT TO SCALE

MAINTAINING TRAFFIC TYPICAL

NO: 102-GEN-NOTES

TRAFFIC TYPICALS
NOTE SHEET

DATE: APRIL 2022
SHEET:

2 OF 2

SIGN NUMBER KEY

 E5-1f 48" x 48" 60" x 48"	 E5-2 48" x 36"	 E5-2a 48" x 36"	 E5-3 48" x 36"	 E13-1P VAR x 24"	 E13-1aP 36" x 24"	 G20-1 60" x 24"	 G20-2 48" x 24"
 G20-4 36" x 18"	 I-6a 18" x 18" 24" x 24" 30" x 30"	 M1-1 18" x 18" 24" x 24" 36" x 36" 48" x 48"	 M1-1 22.5" x 18" 30" x 24" 45" x 36" 60" x 48"	 M1-2 18" x 18" 24" x 24" 36" x 36" 48" x 48"	 M1-2 22.5" x 18" 30" x 24" 45" x 36" 60" x 48"	 M1-3 18" x 18" 24" x 24" 36" x 36" 48" x 48"	 M1-3 22.5" x 18" 30" x 24" 45" x 36" 60" x 48"
 M1-4 18" x 18" 24" x 24" 36" x 36" 48" x 48"	 M1-4 22.5" x 18" 30" x 24" 45" x 36" 60" x 48"	 M1-5 18" x 18" 24" x 24" 30" x 30" 36" x 36"	 M1-5a 18" x 18" 24" x 24"	 M1-6 18" x 18" 24" x 24" 36" x 36"	 M1-6 22.5" x 18" 30" x 24" 45" x 36"	 M3-1 12" x 6" 18" x 9" 24" x 12" 30" x 15" 36" x 18"	 M3-2 12" x 6" 18" x 9" 24" x 12" 30" x 15" 36" x 18"
 M3-3 12" x 6" 18" x 9" 24" x 12" 30" x 15" 36" x 18"	 M3-4 12" x 6" 18" x 9" 24" x 12" 30" x 15" 36" x 18"	 M4-1 12" x 6" 18" x 9" 24" x 12" 30" x 15" 36" x 18"	 M4-1a 12" x 6" 18" x 9" 24" x 12" 30" x 15" 36" x 18"	 M4-2 12" x 6" 18" x 9" 24" x 12" 30" x 15" 36" x 18"	 M4-3 12" x 6" 18" x 9" 24" x 12" 30" x 15" 36" x 18"	 M4-4 18" x 9" 24" x 12" 30" x 15" 36" x 18"	 M4-5 12" x 6" 18" x 9" 24" x 12" 30" x 15" 36" x 18"
 M4-6 12" x 6" 18" x 9" 24" x 12" 30" x 15" 36" x 18"	 M4-7 12" x 6" 18" x 9" 24" x 12" 30" x 15" 36" x 18"	 M4-7a 12" x 6" 18" x 9" 24" x 12" 30" x 15" 36" x 18"	 M4-8 12" x 6" 18" x 9" 24" x 12" 30" x 15"	 M4-8a 24" x 18"	 M4-8b 24" x 12"	 M4-9L 30" x 24" 48" x 36" 60" x 48"	 M4-9R 30" x 24" 48" x 36" 60" x 48"
 M4-9j 30" x 24" 48" x 36" 60" x 48"	 M4-9kL 30" x 30" 48" x 42" 60" x 54"	 M4-9kR 30" x 30" 48" x 42" 60" x 54"	 M4-9mL 30" x 30" 48" x 42" 60" x 54"	 M4-9mR 30" x 30" 48" x 42" 60" x 54"	 M4-9dL 12" x 18"	 M4-9dR 12" x 18"	 M4-9e 12" x 18"
 M4-9f 12" x 18"	 M4-9gL 12" x 18"	 M4-9gR 12" x 18"	 M4-9h 12" x 24"	 M4-9i 12" x 18"	 M4-10L 48" x 18"	 M4-10R 48" x 18"	 M4-11a 12" x 6" 18" x 9" 24" x 12" 30" x 15" 36" x 18"
 M5-1L 12" x 9" 21" x 15" 30" x 21"	 M5-1R 12" x 9" 21" x 15" 30" x 21"	 M5-2L 12" x 9" 21" x 15" 30" x 21"	 M5-2R 12" x 9" 21" x 15" 30" x 21"	 M5-3 12" x 9" 21" x 15" 30" x 21"	 M6-1L 12" x 9" 18" x 12" 21" x 15" 30" x 21"	 M6-1R 12" x 9" 18" x 12" 21" x 15" 30" x 21"	 M6-2L 12" x 9" 18" x 12" 21" x 15" 30" x 21"
 M6-2R 12" x 9" 18" x 12" 21" x 15" 30" x 21"	 M6-3 12" x 9" 18" x 12" 21" x 15" 30" x 21"	 M6-4 12" x 9" 18" x 12" 21" x 15" 30" x 21"	 M6-5 12" x 9" 18" x 12" 21" x 15" 30" x 21"	 M6-6L 12" x 9" 18" x 12" 21" x 15" 30" x 21"	 M6-6R 12" x 9" 18" x 12" 21" x 15" 30" x 21"	 M6-7L 12" x 9" 18" x 12" 21" x 15" 30" x 21"	 M6-7R 12" x 9" 18" x 12" 21" x 15" 30" x 21"

SEE MDOT SHS 13-WORK ZONE FOR SIGN DETAILS



NOT TO SCALE

MAINTAINING TRAFFIC TYPICAL

NO:

103-GEN-SIGN

TRAFFIC TYPICALS
SIGN SHEET

DATE:
JUNE 2021

SHEET:

1 OF 5

SIGN NUMBER KEY

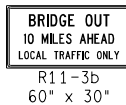
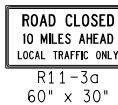
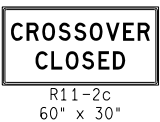
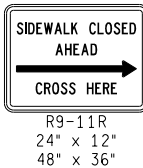
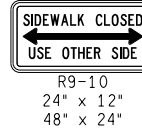
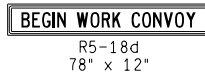
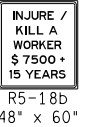
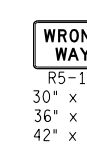
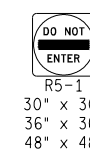
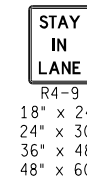
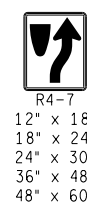
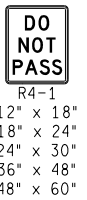
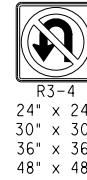
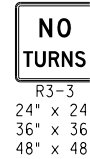
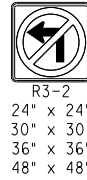
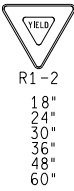
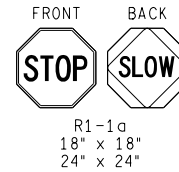
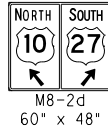

SEE MDOT SHS 13-WORK ZONE FOR SIGN DETAILS



NOT TO SCALE

MAINTAINING TRAFFIC TYPICAL

NO:

103-GEN-SIGN

TRAFFIC TYPICALS SIGN SHEET

DATE: JUNE 2021
SHEET:

SIGN NUMBER KEY



W1-1L
18" x 18"
24" x 24"
30" x 30"
36" x 36"
48" x 48"



W1-1R
18" x 18"
24" x 24"
30" x 30"
36" x 36"
48" x 48"



W1-2L
18" x 18"
24" x 24"
30" x 30"
36" x 36"
48" x 48"



W1-2R
18" x 18"
24" x 24"
30" x 30"
36" x 36"
48" x 48"



W1-2bL
36" x 36"
48" x 48"



W1-2bR
36" x 36"
48" x 48"



W1-3L
18" x 18"
24" x 24"
30" x 30"
36" x 36"
48" x 48"



W1-3R
18" x 18"
24" x 24"
30" x 30"
36" x 36"
48" x 48"



W1-4L
18" x 18"
24" x 24"
30" x 30"
36" x 36"
48" x 48"



W1-4R
18" x 18"
24" x 24"
30" x 30"
36" x 36"
48" x 48"



W1-4bL
24" x 24"
30" x 30"
36" x 36"
48" x 48"



W1-4bR
24" x 24"
30" x 30"
36" x 36"
48" x 48"



W1-4cL
24" x 24"
30" x 30"
36" x 36"
48" x 48"



W1-4cR
24" x 24"
30" x 30"
36" x 36"
48" x 48"



W24-1L
30" x 30"
36" x 36"
48" x 48"

ALL LANES

W24-1cP
24" x 18"
30" x 24"



W24-1R
30" x 30"
36" x 36"
48" x 48"



W24-1aL
30" x 30"
36" x 36"
48" x 48"



W24-1aR
30" x 30"
36" x 36"
48" x 48"



W24-1bL
30" x 30"
36" x 36"
48" x 48"



W24-1bR
30" x 30"
36" x 36"
48" x 48"

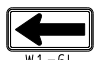

W1-6L
24" x 12"
36" x 18"
48" x 24"
60" x 30"
96" x 48"

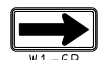

W1-6R
24" x 12"
36" x 18"
48" x 24"
60" x 30"
96" x 48"



W1-8L
12" x 18"
18" x 24"
24" x 30"
30" x 36"
36" x 48"



W1-8R
12" x 18"
18" x 24"
24" x 30"
30" x 36"
36" x 48"



W3-1
18" x 18"
24" x 24"
30" x 30"
36" x 36"
48" x 48"



W3-2
18" x 18"
24" x 24"
30" x 30"
36" x 36"
48" x 48"

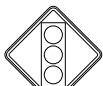

W3-3
18" x 18"
30" x 30"
36" x 36"
48" x 48"



W3-4
30" x 30"
36" x 36"
48" x 48"
60" x 60"



W3-4b
30" x 30"
36" x 36"
48" x 48"



W3-5
36" x 36"
48" x 48"



W3-5a
30" x 30"
36" x 36"
48" x 48"
60" x 60"



W3-5b
30" x 30"
36" x 36"
48" x 48"



W4-1L
24" x 24"
30" x 30"
36" x 36"
48" x 48"



W4-1R
24" x 24"
30" x 30"
36" x 36"
48" x 48"



W4-2L
30" x 30"
36" x 36"
48" x 48"



W4-2R
30" x 30"
36" x 36"
48" x 48"



W4-3L
30" x 30"
36" x 36"
48" x 48"



W4-3R
30" x 30"
36" x 36"
48" x 48"



W4-5L
24" x 24"
30" x 30"
36" x 36"
48" x 48"



W4-5R
24" x 24"
30" x 30"
36" x 36"
48" x 48"



W4-5P
18" x 24"
24" x 30"



W4-6L
24" x 24"
30" x 30"
36" x 36"
48" x 48"



W4-6R
24" x 24"
30" x 30"
36" x 36"
48" x 48"



W4-7L
30" x 30"
36" x 36"
48" x 48"
60" x 60"



W4-7R
30" x 30"
36" x 36"
48" x 48"
60" x 60"



W5-1
30" x 30"
36" x 36"
48" x 48"



W5-2
18" x 18"
30" x 30"
36" x 36"
48" x 48"



W5-3
24" x 24"
30" x 30"
36" x 36"
48" x 48"



W5-4
30" x 30"
36" x 36"
48" x 48"



W6-1
30" x 30"
36" x 36"
48" x 48"



W6-2
30" x 30"
36" x 36"
48" x 48"



W6-3
30" x 30"
36" x 36"
48" x 48"

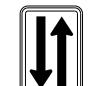

W6-4
12" x 18"



W7-1
24" x 24"
30" x 30"
36" x 36"
48" x 48"



W7-1a
24" x 24"
30" x 30"
36" x 36"
48" x 48"



W8-1
18" x 18"
24" x 24"
30" x 30"
36" x 36"
48" x 48"

SEE MDOT SHS 13-WORK ZONE FOR SIGN DETAILS



NOT TO SCALE

MAINTAINING TRAFFIC TYPICAL

NO:

103-GEN-SIGN

TRAFFIC TYPICAL
SIGN SHEET

DATE:
JUNE 2021

SHEET:

3 OF 5

SIGN NUMBER KEY



W8-2
18" x 18"
24" x 24"
30" x 30"
36" x 36"
48" x 48"



W8-3
18" x 18"
30" x 30"
36" x 36"
48" x 48"



W8-4
18" x 18"
24" x 24"
30" x 30"
36" x 36"
48" x 48"



W8-5
24" x 24"
30" x 30"
36" x 36"
48" x 48"



W8-5P
24" x 18"
30" x 24"
36" x 30"



W8-7
24" x 24"
30" x 30"
36" x 36"
48" x 48"



W8-8
24" x 24"
30" x 30"
36" x 36"
48" x 48"



W8-9
24" x 24"
30" x 30"
36" x 36"
48" x 48"



W8-11
24" x 24"
30" x 30"
36" x 36"
48" x 48"



W8-12
30" x 30"
36" x 36"
48" x 48"



W8-14
24" x 24"
30" x 30"
36" x 36"
48" x 48"



W8-15
24" x 24"
30" x 30"
36" x 36"
48" x 48"



W8-15P
24" x 18"
30" x 24"
36" x 30"



W8-17L
24" x 24"
30" x 30"
36" x 36"
48" x 48"



W8-17R
24" x 24"
30" x 30"
36" x 36"
48" x 48"



W8-17P
24" x 18"
30" x 24"
36" x 30"



W8-18
24" x 24"
36" x 36"
48" x 48"



W8-23
24" x 24"
36" x 36"
48" x 48"



W8-24
30" x 30"
36" x 36"
48" x 48"



W8-25
24" x 24"
30" x 30"
36" x 36"
48" x 48"



W8-26
36" x 36"
48" x 48"



W9-1L
24" x 24"
30" x 30"
36" x 36"
48" x 48"



W9-1R
24" x 24"
30" x 30"
36" x 36"
48" x 48"



W9-2L
30" x 30"
36" x 36"
48" x 48"



W9-2R
30" x 30"
36" x 36"
48" x 48"



W9-3C
30" x 30"
36" x 36"
48" x 48"
60" x 60"



W9-3L
30" x 30"
36" x 36"
48" x 48"
60" x 60"



W9-3R
30" x 30"
36" x 36"
48" x 48"
60" x 60"



W9-3a
30" x 30"
36" x 36"
48" x 48"
60" x 60"



W9-3b
30" x 30"
36" x 36"
48" x 48"
60" x 60"



W11-10
24" x 24"
30" x 30"
36" x 36"
48" x 48"



W11-10a
30" x 30"
36" x 36"
48" x 48"



W11-24
36" x 36"
48" x 48"



W12-1
24" x 24"
30" x 30"
36" x 36"
48" x 48"



W12-2
18" x 18"
24" x 24"
30" x 30"
36" x 36"
48" x 48"



W13-1P
18" x 18"
24" x 24"
30" x 30"



W13-2
24" x 30"
36" x 48"
48" x 60"

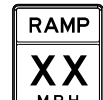

W13-3
24" x 30"
36" x 48"
48" x 60"



W13-4P
24" x 24"
36" x 36"



W13-6
24" x 42"
36" x 60"
48" x 84"



W13-6a
24" x 42"
36" x 60"
48" x 84"

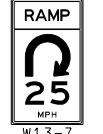

W13-7
24" x 42"
36" x 60"
48" x 84"

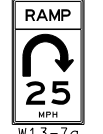

W13-7a
24" x 42"
36" x 60"
48" x 84"



W14-3
36" x 24"
40" x 30"
48" x 36"
64" x 48"



W16-2P
18" x 12"
24" x 18"
30" x 24"



W16-4aP
18" x 12"
24" x 18"
30" x 24"
36" x 30"



W16-12P
24" x 18"



W16-13P
24" x 18"
30" x 24"



W20-1
24" x 24"
30" x 30"
36" x 36"
48" x 48"
60" x 60"



W20-1a
24" x 24"
30" x 30"
36" x 36"
48" x 48"
60" x 60"



W20-1b
24" x 24"
30" x 30"
36" x 36"
48" x 48"
60" x 60"



W20-1c
24" x 24"
30" x 30"
36" x 36"
48" x 48"
60" x 60"



W20-1d
24" x 24"
30" x 30"
36" x 36"
48" x 48"
60" x 60"



W20-2
30" x 30"
36" x 36"
48" x 48"



W20-3
30" x 30"
36" x 36"
48" x 48"



W20-3a
30" x 30"
36" x 36"
48" x 48"

SEE MDOT SHS 13-WORK ZONE FOR SIGN DETAILS



NOT TO SCALE

MAINTAINING TRAFFIC TYPICAL

NO:

103-GEN-SIGN

TRAFFIC TYPICALS
SIGN SHEET

DATE:
JUNE 2021
SHEET:

4 OF 5

SIGN NUMBER KEY



W20-3b
30" x 30"
36" x 36"
48" x 48"



W20-4
30" x 30"
36" x 36"
48" x 48"



W20-4c
36" x 36"
48" x 48"



W20-5C
30" x 30"
36" x 36"
48" x 48"



W20-5L
30" x 30"
36" x 36"
48" x 48"



W20-5L1
30" x 30"
36" x 36"
48" x 48"



W20-5L2
30" x 30"
36" x 36"
48" x 48"



W20-5R
30" x 30"
36" x 36"
48" x 48"



W20-5R1
30" x 30"
36" x 36"
48" x 48"



W20-5R2
30" x 30"
36" x 36"
48" x 48"



W20-5aL2
30" x 30"
36" x 36"
48" x 48"



W20-5aL3
30" x 30"
36" x 36"
48" x 48"



W20-5aR2
30" x 30"
36" x 36"
48" x 48"



W20-5aR3
30" x 30"
36" x 36"
48" x 48"



W20-7a
30" x 30"
36" x 36"
48" x 48"



W20-8
24" x 18"

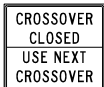

W20-9
54" x 48"



W20-10
48" x 24"
66" x 30"



W20-11
12" x 18"



W20-12P
VARIABLE x 12"



W20-13P
VARIABLE x 12"



W20-14L
36" x 36"
48" x 48"



W20-14R
36" x 36"
48" x 48"



W20-14dP
36" x 12"
48" x 12"



W20-14bP
36" x 12"
48" x 12"



W20-15
36" x 36"
48" x 48"



W20-15a
36" x 36"
48" x 48"



W20-15c
48" x 54"



W20-15d
48" x 54"



W20-16
36" x 36"
48" x 48"



W20-17
36" x 36"
48" x 48"



W21-1
24" x 24"
30" x 30"
36" x 36"
48" x 48"



W21-2
24" x 24"
30" x 30"
36" x 36"
48" x 48"



W21-2
24" x 24"
30" x 30"
36" x 36"
48" x 48"



W21-3
24" x 24"
30" x 30"
36" x 36"
48" x 48"



W21-4
36" x 18"



W21-5
24" x 24"
30" x 30"
36" x 36"
48" x 48"



W21-5aL
30" x 30"
36" x 36"
48" x 48"
60" x 60"



W21-5aR
30" x 30"
36" x 36"
48" x 48"
60" x 60"



W21-5bL
30" x 30"
36" x 36"
48" x 48"
60" x 60"



W21-5bR
30" x 30"
36" x 36"
48" x 48"
60" x 60"



W21-6
24" x 24"
30" x 30"
36" x 36"
48" x 48"



W21-7
30" x 30"
36" x 36"
48" x 48"



W21-8
30" x 30"
36" x 36"
48" x 48"



W22-1
30" x 30"
36" x 36"
48" x 48"



W22-2
42" x 36"



W22-3
36" x 30"
42" x 36"



W23-1
48" x 24"



W23-2
36" x 36"
48" x 48"

SEE MDOT SHS 13-WORK ZONE FOR SIGN DETAILS



NOT TO SCALE

MAINTAINING TRAFFIC TYPICAL

NO:

103-GEN-SIGN

TRAFFIC TYPICAL
SIGN SHEET

DATE:
JUNE 2021

SHEET:

5 OF 5

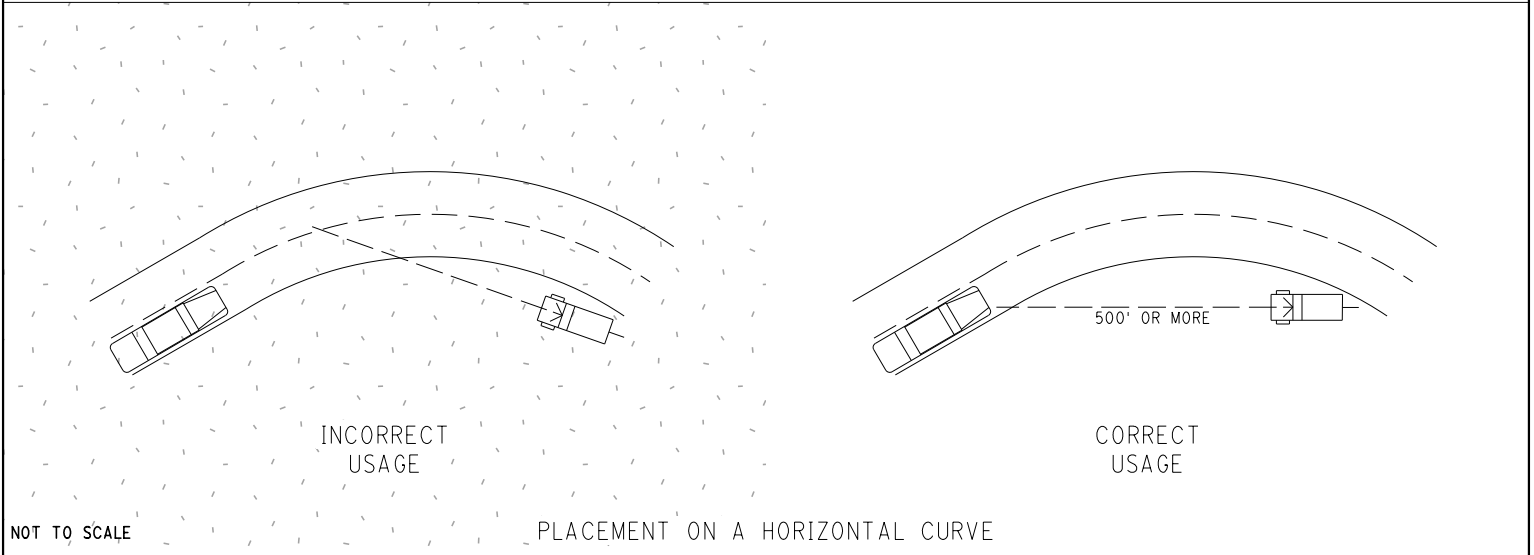
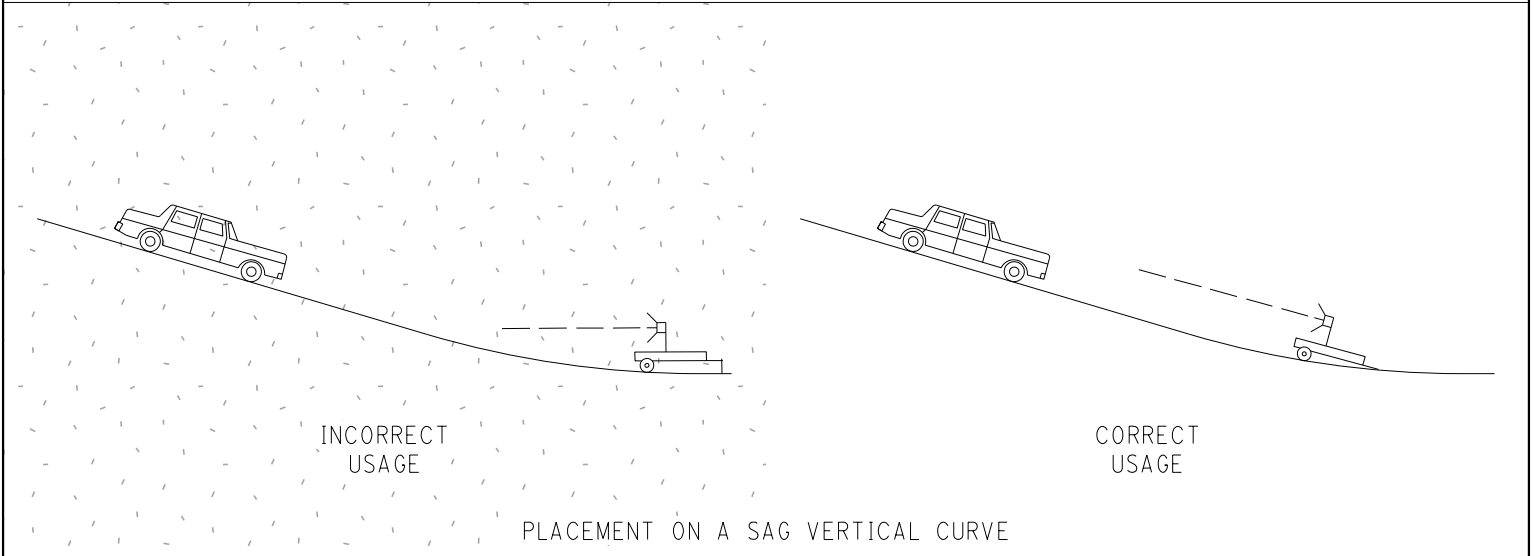
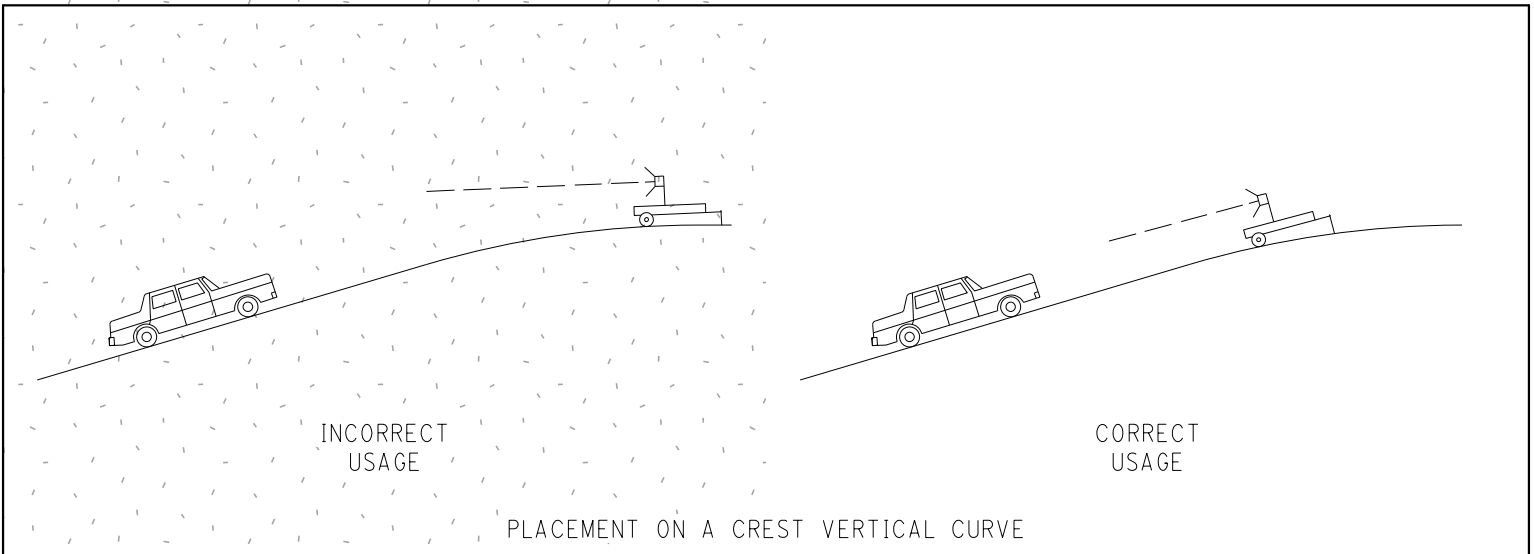

NOTE:

ENSURE THE ARROW REMAINS CLEARLY LEGIBLE AT DISTANCES FROM 2,500 FEET TO 200 FEET, FROM ALL TRAFFIC LANES AND ROADWAY ENTRANCES. DO NOT PLACE THE LIGHTED ARROW ON A HORIZONTAL OR VERTICAL CURVE THAT MIGHT INTERFERE WITH THIS LEGIBILITY REQUIREMENT.

	NOT TO SCALE	MAINTAINING TRAFFIC TYPICAL	USE OF ARROW BOARD ON HILL OR CURVE AND WORK ZONE LAYOUT	DATE: MAY 2021
		NO: 104-GEN-AB		SHEET:
FILE: 104-GEN-AB.dgn				1 OF 1

NO SPEED REDUCTION THROUGH WORK ZONE

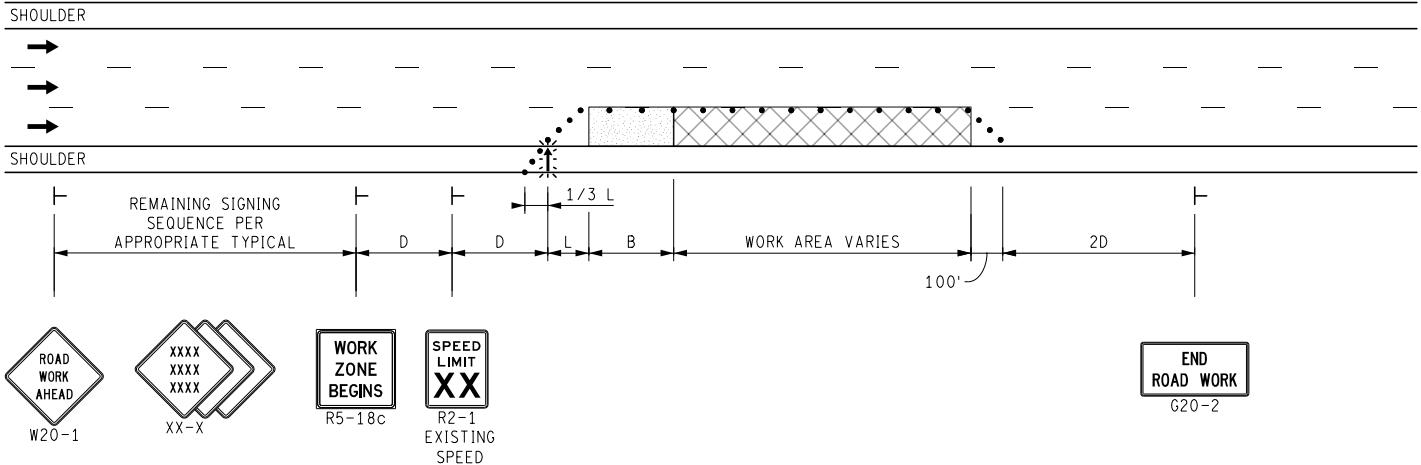

REDUCED SPEED THROUGH WORK ZONE

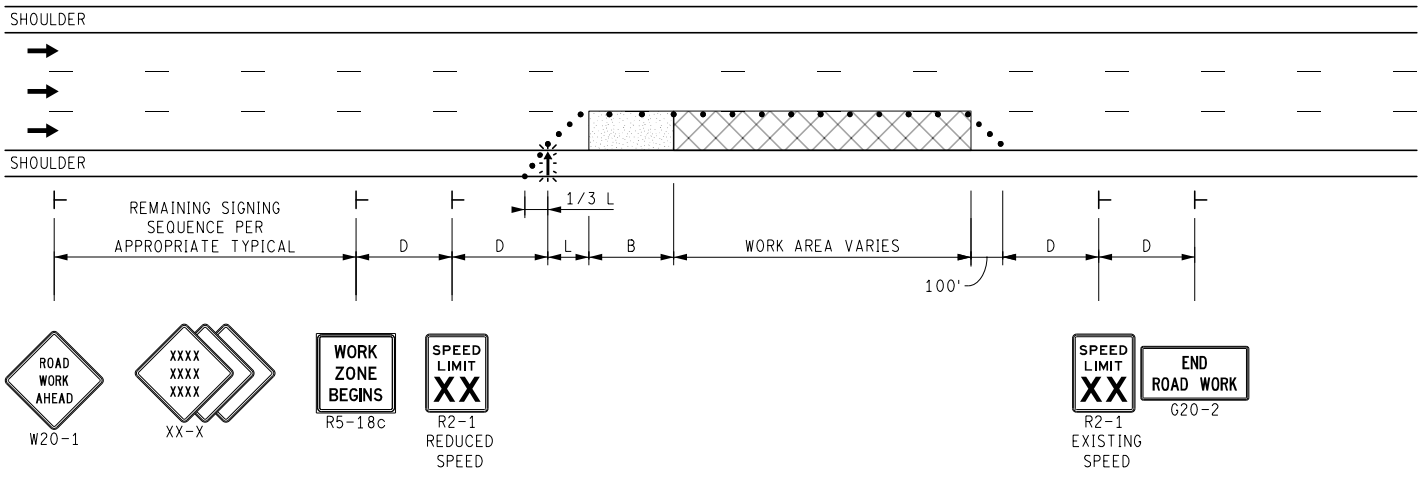

REDUCED SPEED THROUGH WORK ZONE USING "WHERE WORKERS PRESENT"

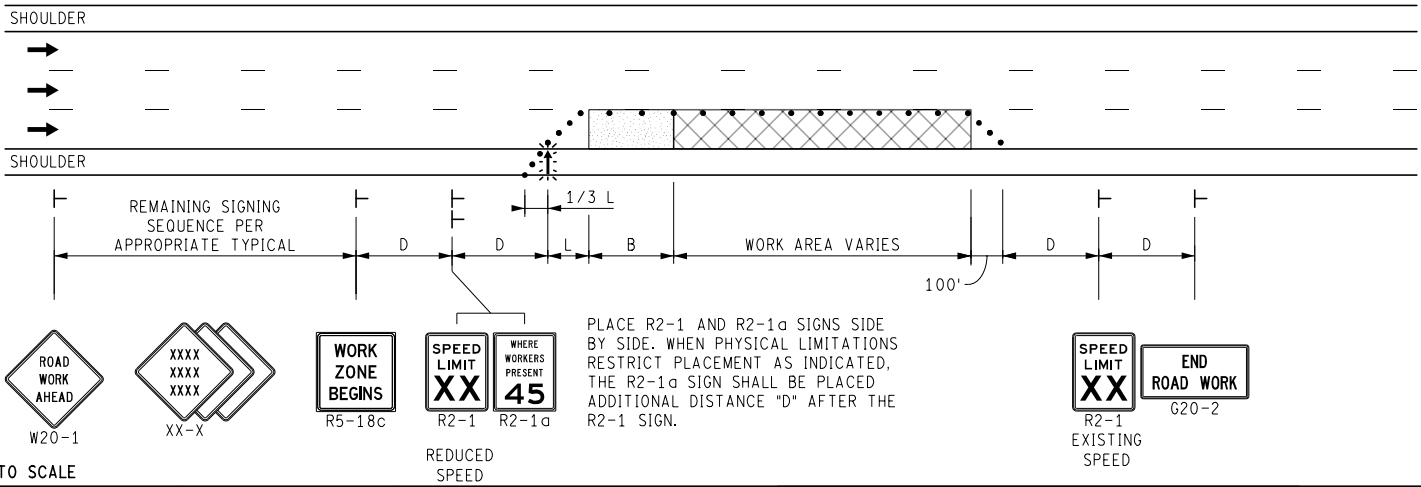

NOT TO SCALE



NOT TO SCALE

MAINTAINING TRAFFIC TYPICAL

NO: **107-GEN-SPEED**

SPEED LIMIT LAYOUT

DATE: MAY 2021
SHEET: 1 OF 2

REDUCED SPEED FROM 75 TO 60 THROUGH WORK ZONE

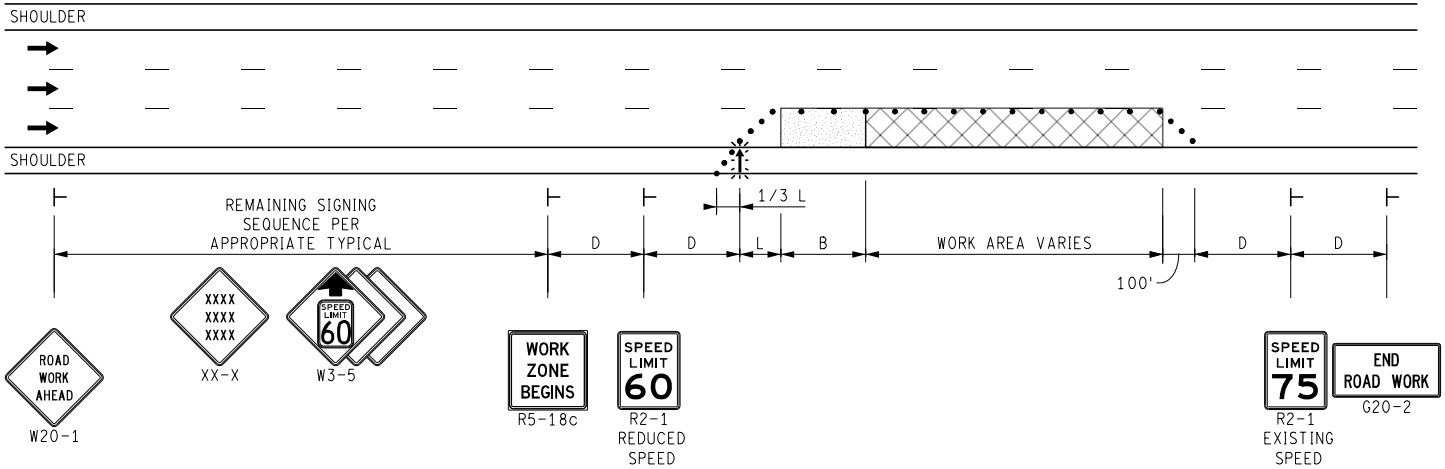

REDUCED SPEED FROM 75 TO 45 WWP THROUGH WORK ZONE

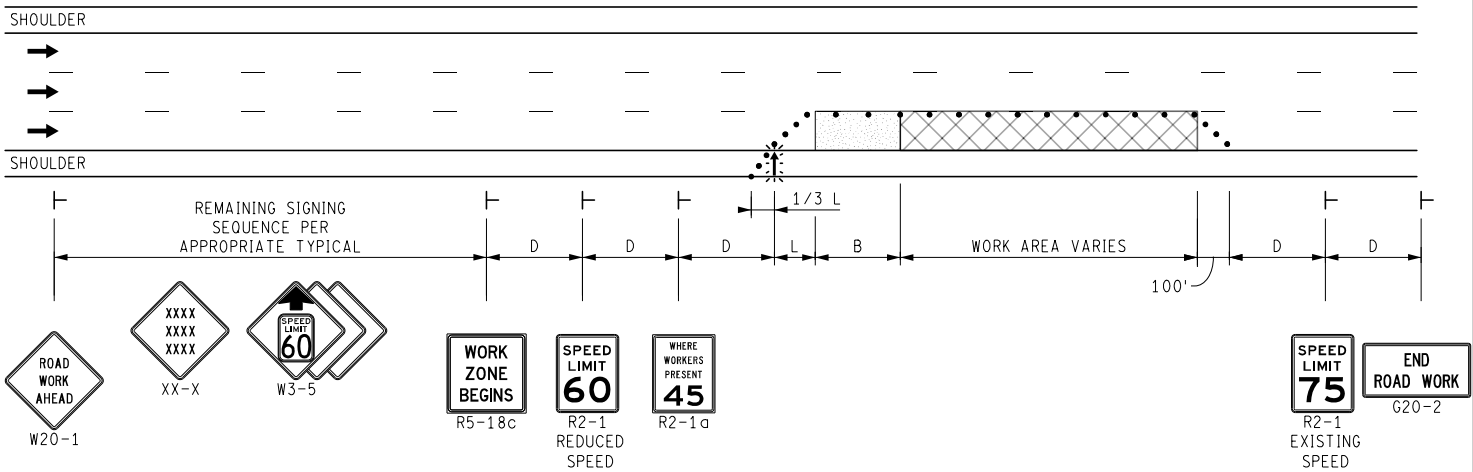

NOT TO SCALE



NOT TO SCALE

MAINTAINING TRAFFIC TYPICAL

NO: 107-GEN-SPEED

SPEED LIMIT LAYOUT

DATE: MAY 2021
SHEET:

FILE: 107-GEN-SPEED.dgn

2 OF 2

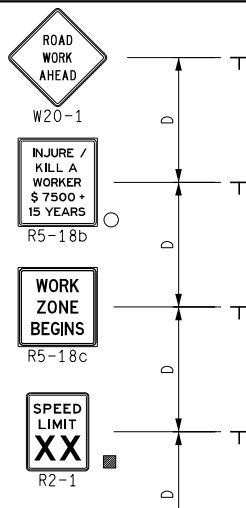

- KEY**
- CHANNELIZING DEVICES
 - ⚡ LIGHTED ARROW PANEL (CAUTION MODE)
 - ← TRAFFIC FLOW
 - REFLECTS EXISTING SPEED LIMIT
 - PLACE SIGN AS INDICATED IN NOTE S2

STANDARD NOTES
 (SEE 102-GEN-NOTES)
 GENERAL: G1, G2, G3, G4
 SIGNING: S1, S2, S3, S5
 DEVICES: TCD1, TCD2, TCD6, TCD7

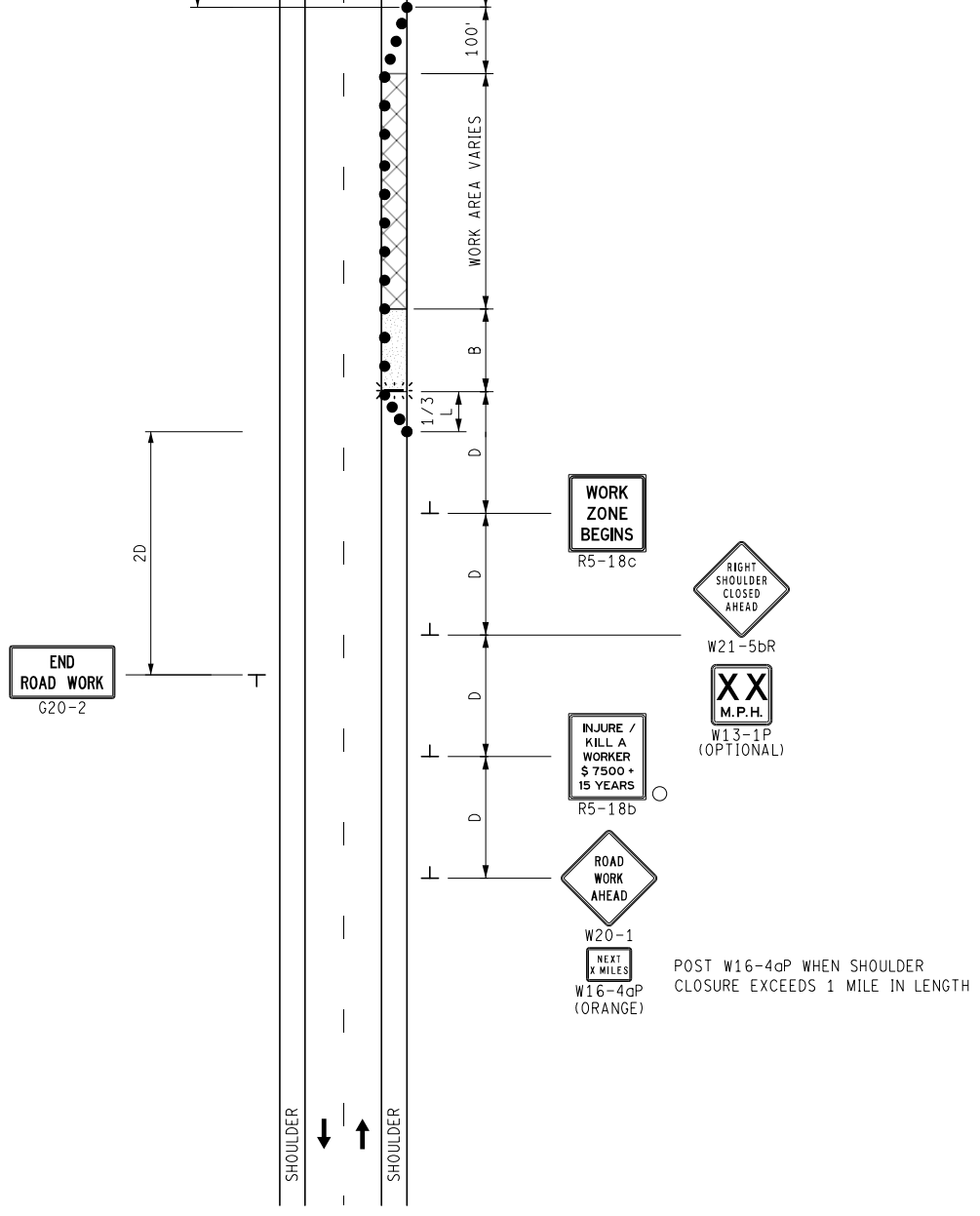

POST W16-4aP WHEN SHOULDER CLOSURE EXCEEDS 1 MILE IN LENGTH

KEY

- CHANNELIZING DEVICES
- ⚡ LIGHTED ARROW PANEL (CAUTION MODE)
- ← TRAFFIC FLOW
- REFLECTS EXISTING SPEED LIMIT
- PLACE SIGN AS INDICATED IN NOTE S2.

STANDARD NOTES

(SEE 102-GEN-NOTES)

GENERAL: G1, G2, G3, G4
 SIGNING: S1, S3, S5
 DEVICES: TCD1, TCD2, TCD6

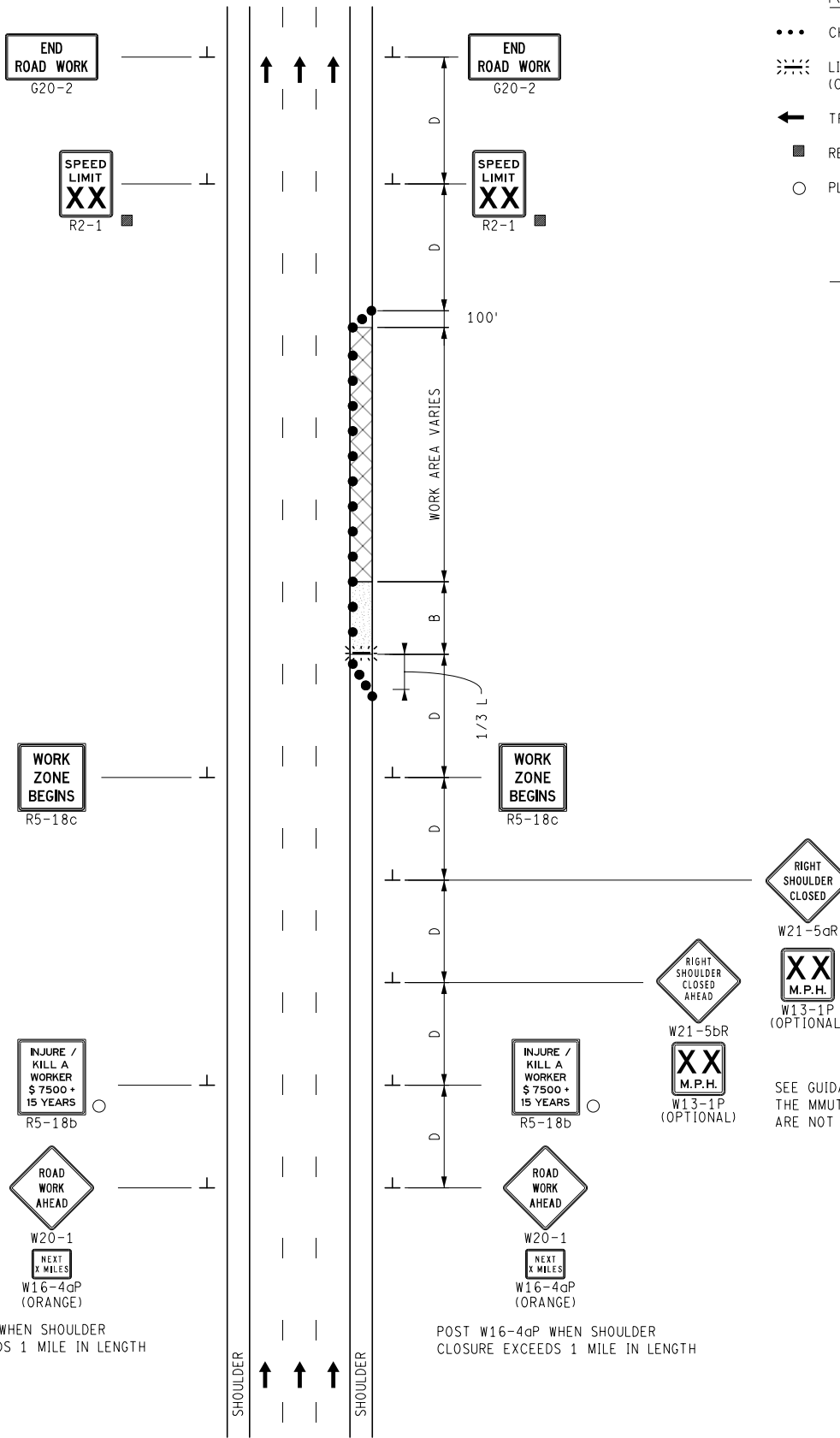

SEE GUIDANCE NOTE 03 IN SECTION 66.07 OF THE MMUTCD FOR WHY THE SIGNS ON THE LEFT ARE NOT NEEDED

KEY

- CHANNELIZING DEVICES
- ← TRAFFIC FLOW
- △ PLACE TYPE III BARRICADES AS INDICATED IN NOTE TCD7

STANDARD NOTES

(SEE 102-GEN-NOTES)

GENERAL: G1, G2, G3, G4
 SIGNING: S1, S6
 DEVICES: TCD1, TCD2, TCD3, TCD7



SIGN MATERIAL SELECTION TABLE

SIGN SIZE	SIGN MATERIAL TYPE		
	TYPE I	TYPE II	TYPE III
≤ 36" X 36"		X	X
>36" X 36" ≤ 96" TO WIDE		X	
> 96" WIDE TO 144" WIDE	X	X	
> 144" WIDE	X		

TYPE I ALUMINUM EXTRUSION
 TYPE II PLYWOOD
 TYPE III ALUMINUM SHEET

ROUNDING OF CORNERS IS NOT REQUIRED FOR TYPE I OR II SIGNS.
 VERTICAL JOINTS ARE NOT PERMITTED.
 HORIZONTAL JOINTS THROUGH SIGN LEGEND OR SYMBOLS ARE NOT PERMITTED.

POST SIZE REQUIREMENTS TABLE

SIGN AREA (ft ²)	POST TYPE		
	U-CHANNEL STEEL	SQUARE TUBULAR STEEL	WOOD
≤ 9	1 - 3 lb/ft*	1 - 2" 12 or 14 GA*	N/A
9 ≤ 20	2 - 3 lb/ft	2 - 2" 12 or 14 GA	1 - 4" X 6"*
> 20 ≤ 30	N/A	N/A	2 - 4" X 6"
> 30 ≤ 60	N/A	N/A	2 - 6" X 8"
> 60 ≤ 84	N/A	N/A	3 - 6" X 8"

*SIGNS 4 FEET AND GREATER IN WIDTH REQUIRE 2 POSTS.
 SIGNS GREATER THAN 8 FEET IN WIDTH REQUIRE 2 OR 3 WOOD
 POSTS DEPENDING ON AREA OF SIGN.
 A MAXIMUM OF 2 POSTS WITHIN A 7' PATH IS PERMITTED.

 PREPARED BY DESIGN DIVISION	DEPARTMENT DIRECTOR Kirk T. Steudle	MICHIGAN DEPARTMENT OF TRANSPORTATION BUREAU OF DEVELOPMENT STANDARD PLAN FOR		
	APPROVED BY: _____ DIRECTOR, BUREAU OF FIELD SERVICES	<h1 style="margin: 0;">GROUND DRIVEN SIGN SUPPORTS FOR TEMP SIGNS</h1>		
DRAWN BY: CON/ECH CHECKED BY: AUG	APPROVED BY: _____ DIRECTOR, BUREAU OF DEVELOPMENT	_____ F.H.W.A. APPROVAL	11/2/2017 PLAN DATE	WZD-100-A SHEET 1 OF 11

2 POST SIGN SUPPORT SPACING

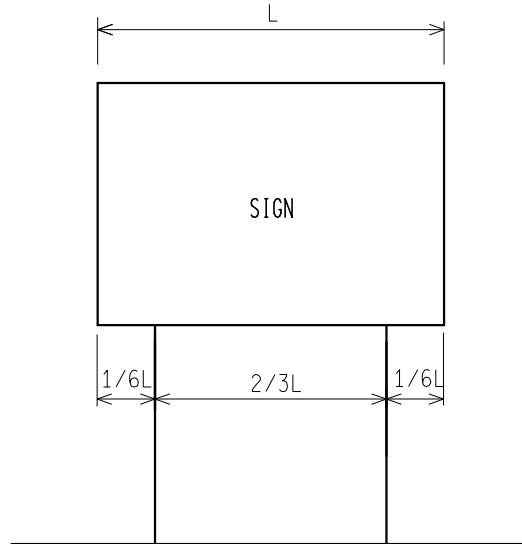

3 POST SIGN SUPPORT SPACING

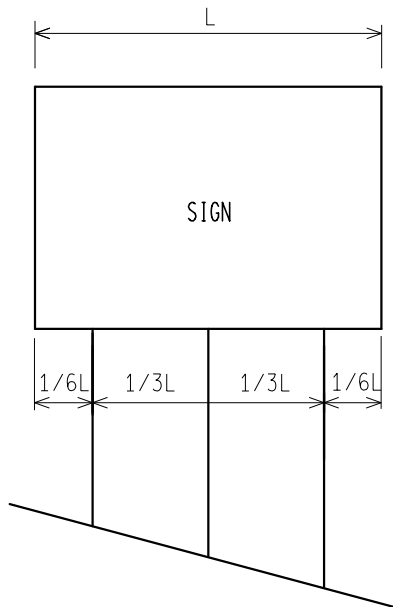

* FOR ALL 11' AND 12' LONG SIGNS ON 3 WOOD SUPPORTS, SPREAD POSTS SO AS TO HAVE A 8' MIN. TO 9' MAX. DISTANCE BETWEEN OUTSIDE POSTS.

NOT TO SCALE

MICHIGAN DEPARTMENT OF TRANSPORTATION
BUREAU OF DEVELOPMENT STANDARD PLAN

F.H.W.A. APPROVAL

11/2/2017
PLAN DATE

WZD-100-A

SHEET
2 OF 11

NOTE: THE ORIGINAL SIGNED COPY IS KEPT ON FILE AT THE MICHIGAN DEPARTMENT OF TRANSPORTATION.

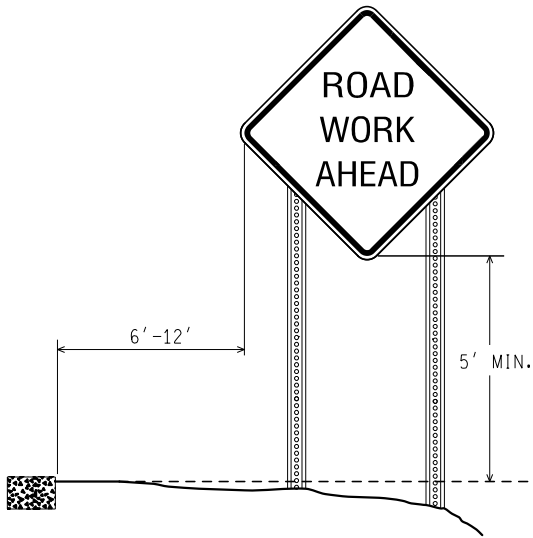

RURAL

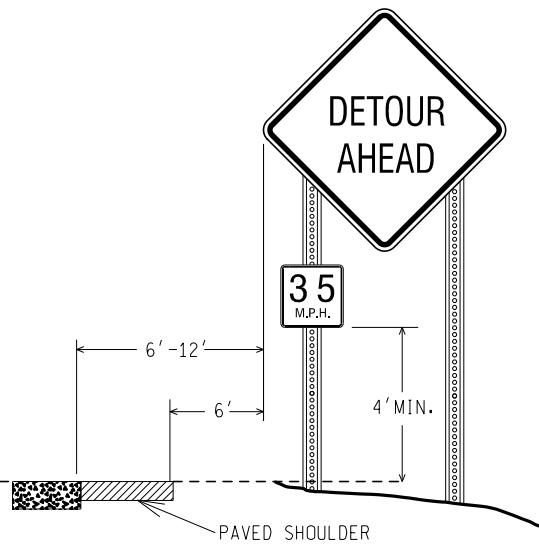

RURAL WITH ADVISORY SPEED PLATE

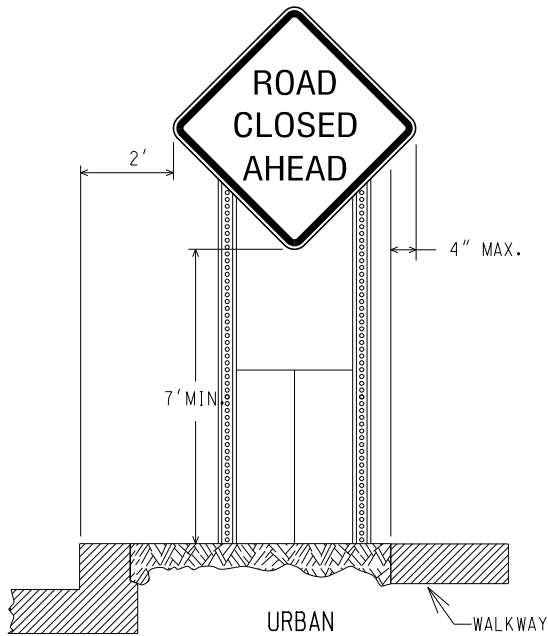

(CURBED AREAS OR WHERE WALKWAYS ARE PRESENT)

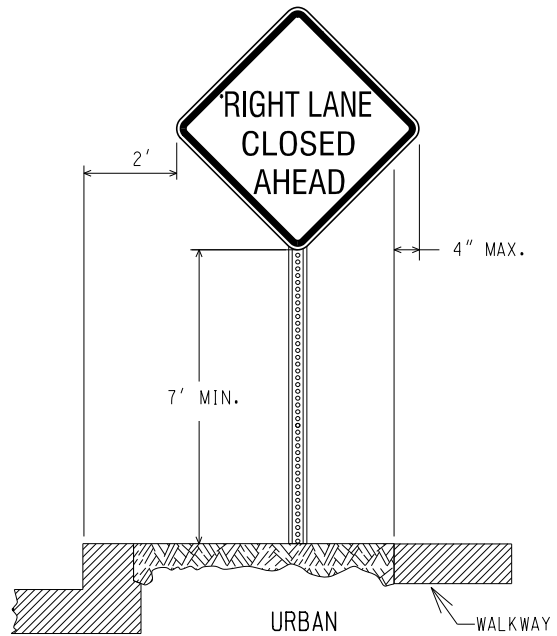

(CURBED AREAS OR WHERE WALKWAYS ARE PRESENT)

BOTTOM HEIGHT AND OFFSET

NOT TO SCALE

MICHIGAN DEPARTMENT OF TRANSPORTATION
BUREAU OF DEVELOPMENT STANDARD PLAN

F.H.W.A. APPROVAL

11/2/2017
PLAN DATE

WZD-100-A

SHEET
3 OF 11

NOTE: THE ORIGINAL SIGNED COPY IS KEPT ON FILE AT THE MICHIGAN DEPARTMENT OF TRANSPORTATION.

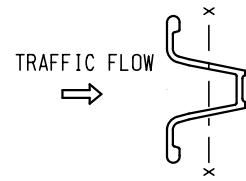
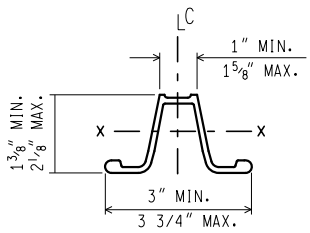
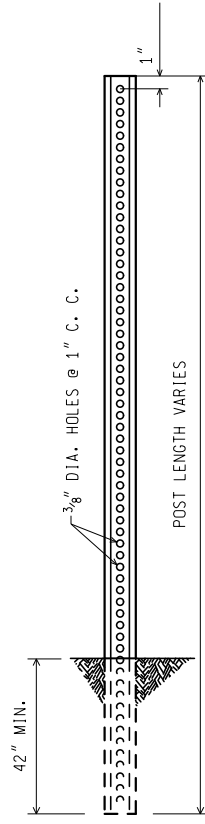

WEIGHT = 3 lbs/ft
 SECT. MOD. X.-X. = 0.31 CUBIC INCHES MIN.

3 lb. U - CHANNEL STEEL POST
 (NO SPLICE)

MOUNT SIGN ON OPEN FACE OF
 U - CHANNEL STEEL POST

NOT TO SCALE

MICHIGAN DEPARTMENT OF TRANSPORTATION BUREAU OF DEVELOPMENT STANDARD PLAN	F.H.W.A. APPROVAL	11/2/2017 PLAN DATE	WZD-100-A	SHEET 4 OF 11
--	-------------------	------------------------	-----------	------------------

NOTE: THE ORIGINAL SIGNED COPY IS KEPT ON FILE AT THE MICHIGAN DEPARTMENT OF TRANSPORTATION.

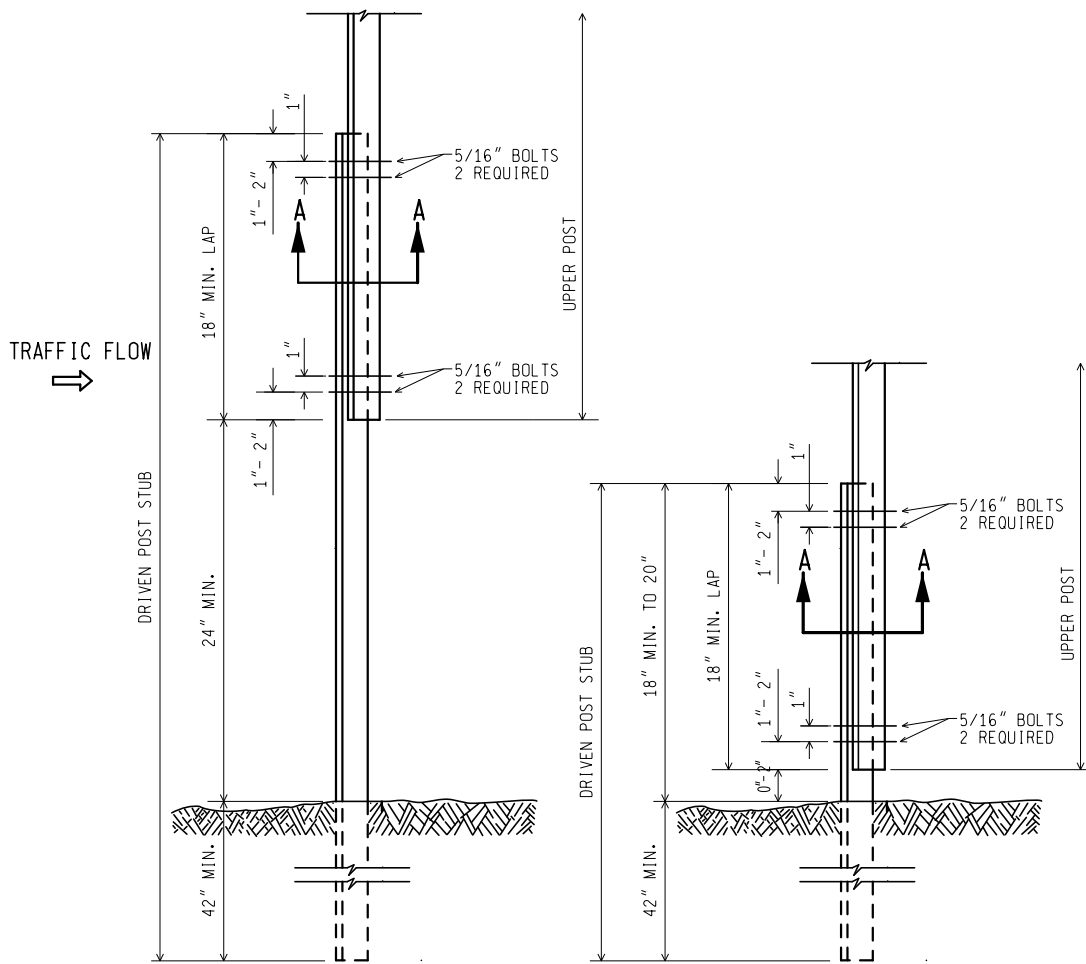

3 lb. U - CHANNEL STEEL POST
(WITH SPLICE)

MOUNT SIGN ON OPEN FACE OF
UPPER U - CHANNEL STEEL POST

NOT TO SCALE

MICHIGAN DEPARTMENT OF TRANSPORTATION BUREAU OF DEVELOPMENT STANDARD PLAN	F.H.W.A. APPROVAL	11/2/2017 PLAN DATE	WZD-100-A	SHEET 5 OF 11
--	-------------------	------------------------	-----------	------------------

NOTE: THE ORIGINAL SIGNED COPY IS KEPT ON FILE AT THE MICHIGAN DEPARTMENT OF TRANSPORTATION.

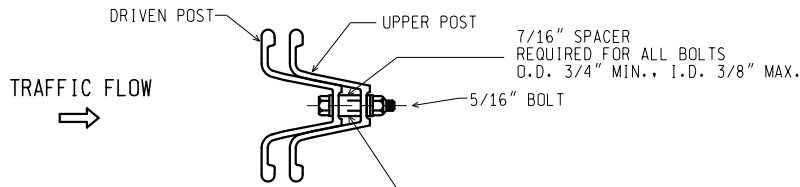

SECTION A-A

7/16" SPACER
 REQUIRED FOR ALL BOLTS
 O.D. 3/4" MIN., I.D. 3/8" MAX.

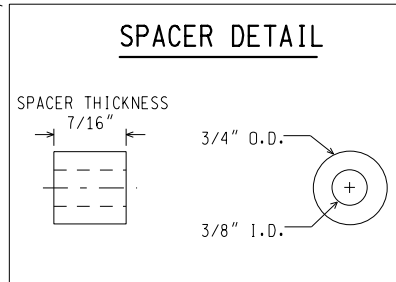

NOTES:

1. THE SPACER THICKNESS SHALL BE 1/16" LESS THAN THE GAP BETWEEN THE POST WHEN POSITIONED IN THE UNBOLTED CONFIGURATION.
2. THE EXTERIOR BOLT (CLOSEST TO LAP), SPACER, WASHER, AND NUT SHALL BE INSTALLED IN A PREPUNCHED HOLE 1" TO 2" FROM THE END OF THE LAP.
3. THE INTERIOR BOLT (FARTHEST FROM LAP), SPACER, WASHER, AND NUT SHALL BE INSTALLED IN THE NEXT PREPUNCHED HOLE.
4. THE DRIVEN POST SHALL ALWAYS BE MOUNTED IN FRONT OF THE UPPER POST WITH RESPECT TO THE ADJACENT ONCOMING TRAFFIC, REGARDLESS OF THE DIRECTION THE SIGN IS FACING.
5. THE SPLICE LAP SHALL BE FASTENED BY FOUR-5/16" DIA. GALVANIZED A449 BOLTS (SAE J429 GRADE 5) OR GALVANIZED A325 BOLTS.

3 lb. U - CHANNEL STEEL POST
 (WITH SPLICE)

NOT TO SCALE

MICHIGAN DEPARTMENT OF TRANSPORTATION BUREAU OF DEVELOPMENT STANDARD PLAN	F.H.W.A. APPROVAL	11/2/2017 PLAN DATE	WZD-100-A	SHEET 6 OF 11
--	-------------------	------------------------	-----------	------------------

NOTE: THE ORIGINAL SIGNED COPY IS KEPT ON FILE AT THE MICHIGAN DEPARTMENT OF TRANSPORTATION.

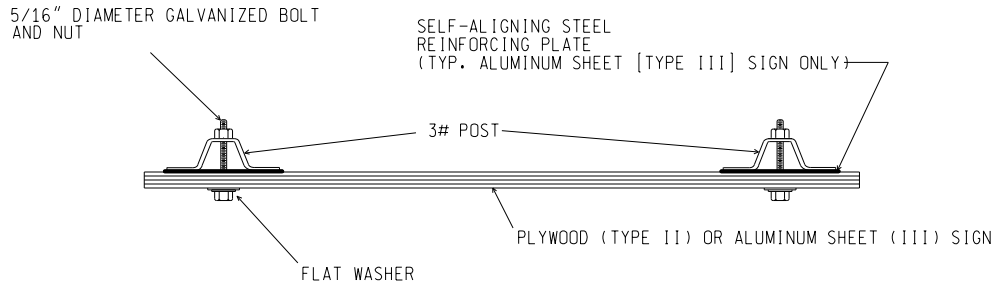

SIGN TO 3 lb. POST CONNECTION

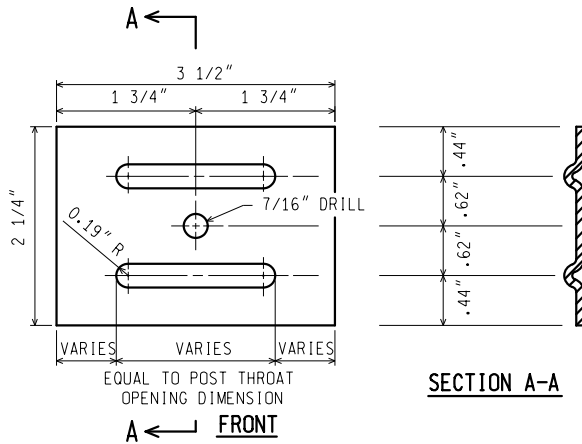

NOTES: (FOR STEEL SIGN REINF' PLATE)

1. MATERIAL: 12 GAUGE CARBON STEEL.
2. TOLERANCE ON ALL DIMENSIONS $\pm 0.0625"$
3. FINISH-AFTER STAMPING AND PUNCHING, GALVANIZE ACCORDING TO CURRENT SPECIFICATIONS FOR ZINC (HOT GALVANIZE) COATINGS ON PRODUCTS FABRICATED FROM PLATES OR STRIPS

STEEL SIGN REINFORCING PLATE
REQUIRED FOR TYPE III SIGNS ONLY

3 lb. U - CHANNEL STEEL POST SIGN CONNECTION

NOT TO SCALE

MICHIGAN DEPARTMENT OF TRANSPORTATION
BUREAU OF DEVELOPMENT STANDARD PLAN

F.H.W.A. APPROVAL

11/2/2017
PLAN DATE

WZD-100-A

SHEET
7 OF 11

NOTE: THE ORIGINAL SIGNED COPY IS KEPT ON FILE AT THE MICHIGAN DEPARTMENT OF TRANSPORTATION.

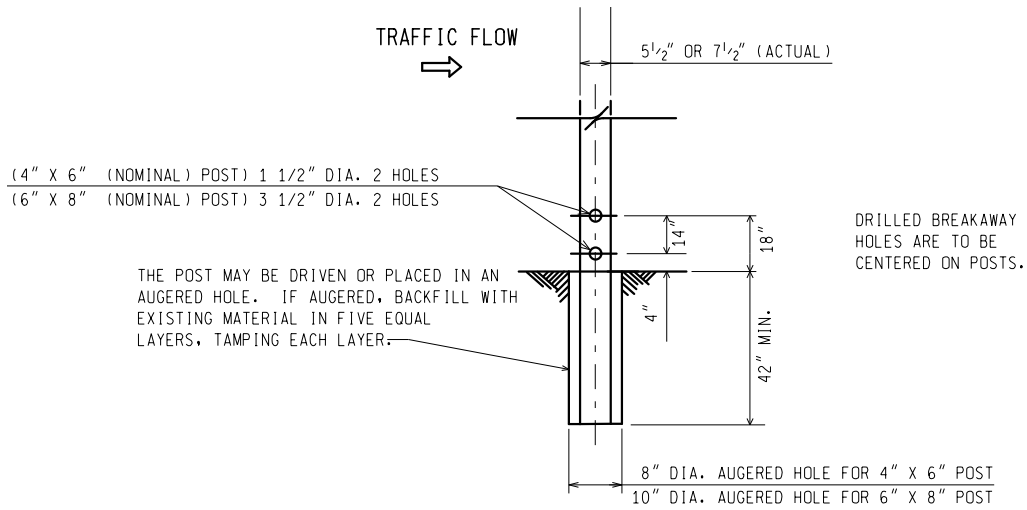

**WOOD POST BREAKAWAY HOLES/
DIRECT EMBEDMENT DETAILS**

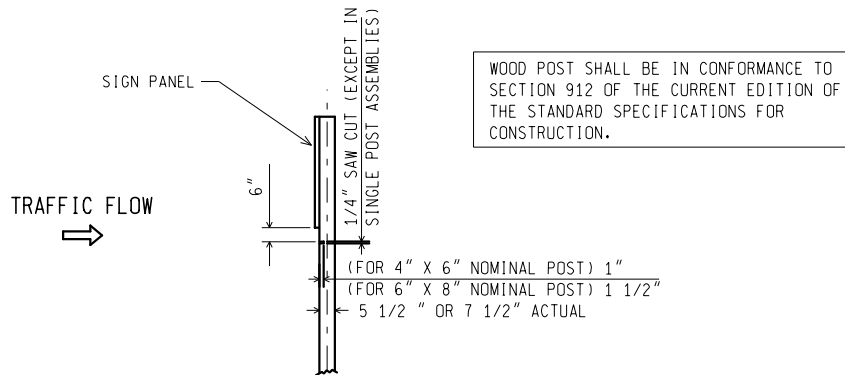

**SAW CUT DETAIL
(MULTIPLE POST INSTALLATIONS)**

WOOD POST DETAILS

NOT TO SCALE

MICHIGAN DEPARTMENT OF TRANSPORTATION
BUREAU OF DEVELOPMENT STANDARD PLAN

F.H.W.A. APPROVAL

11/2/2017
PLAN DATE

WZD-100-A

SHEET
8 OF 11

NOTE: THE ORIGINAL SIGNED COPY IS KEPT ON FILE AT THE MICHIGAN DEPARTMENT OF TRANSPORTATION.

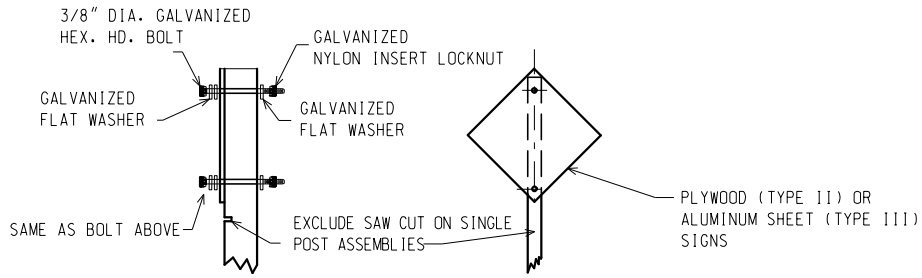

TYPE II AND TYPE III SIGNS

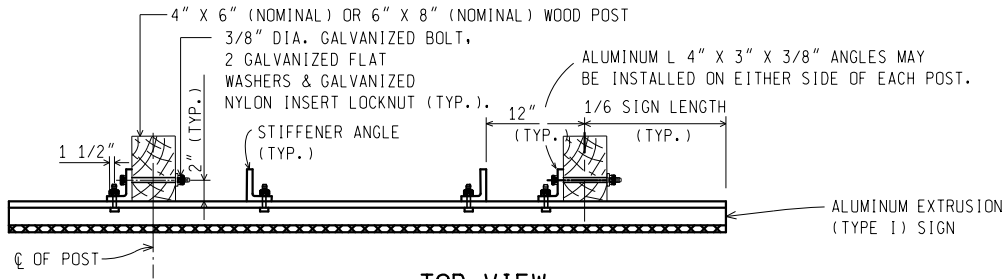

**TOP VIEW
TYPE I SIGN**

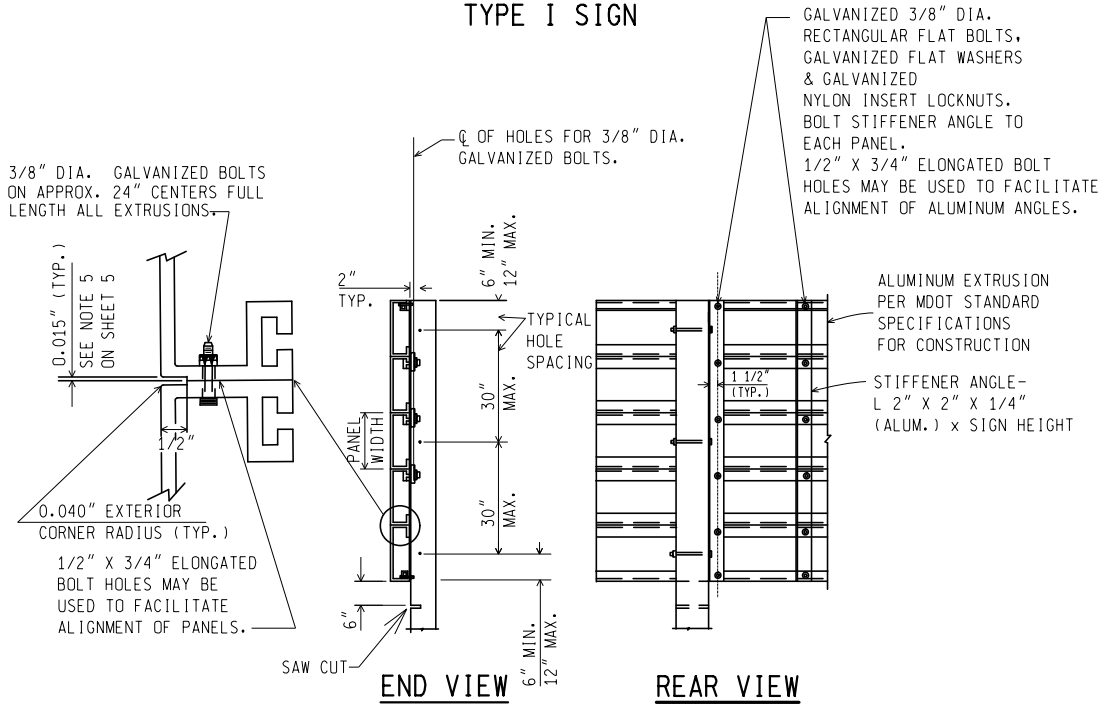

TYPE I SIGN - ERECTION DETAILS

WOOD POST CONNECTIONS

NOT TO SCALE

MICHIGAN DEPARTMENT OF TRANSPORTATION
BUREAU OF DEVELOPMENT STANDARD PLAN

F.H.W.A. APPROVAL

11/2/2017
PLAN DATE

WZD-100-A

SHEET
9 OF 11

NOTE: THE ORIGINAL SIGNED COPY IS KEPT ON FILE AT THE MICHIGAN DEPARTMENT OF TRANSPORTATION.

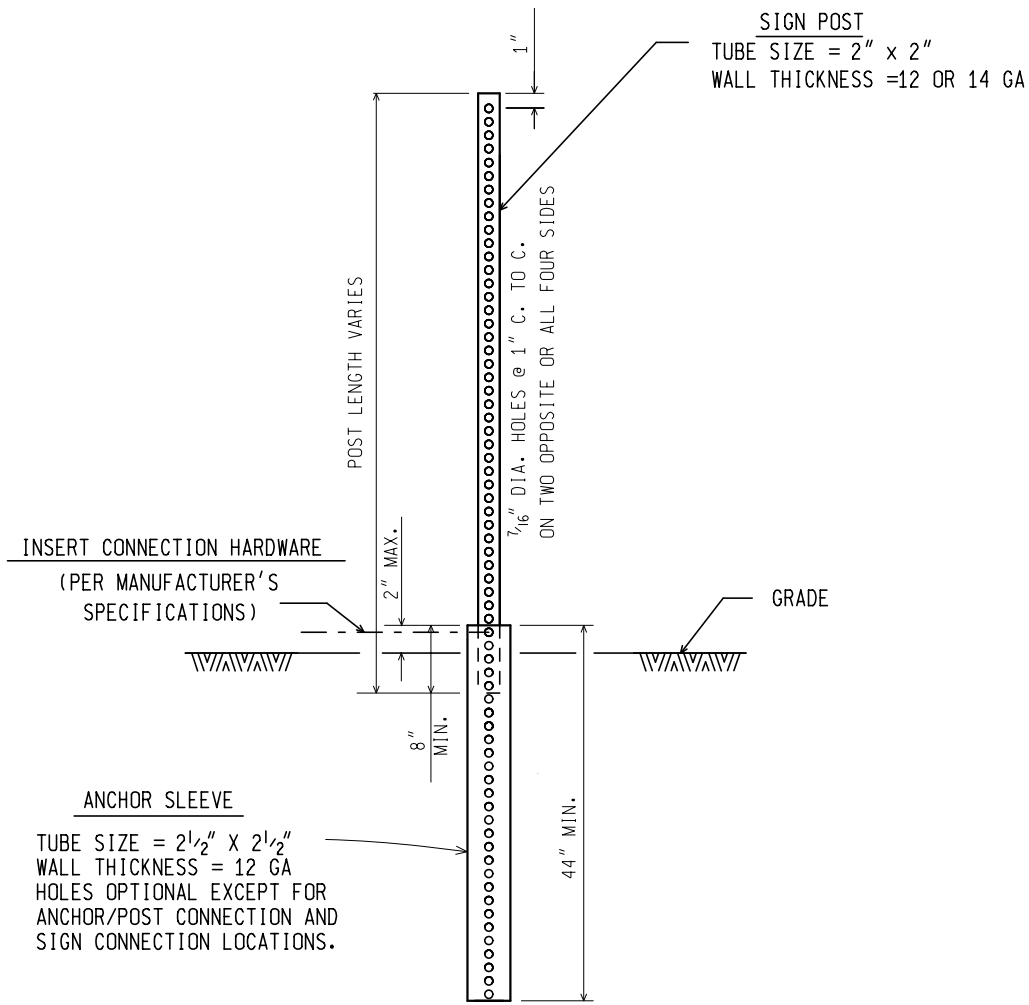

SQUARE TUBULAR STEEL POST

NOT TO SCALE

MICHIGAN DEPARTMENT OF TRANSPORTATION BUREAU OF DEVELOPMENT STANDARD PLAN	F.H.W.A. APPROVAL	11/2/2017 PLAN DATE	WZD-100-A	SHEET 10 OF 11
--	-------------------	------------------------	-----------	-------------------

NOTE: THE ORIGINAL SIGNED COPY IS KEPT ON FILE AT THE MICHIGAN DEPARTMENT OF TRANSPORTATION.

GENERAL NOTES:

1. A MAXIMUM OF TWO POSTS WITHIN A 7 FOOT PATH IS PERMITTED.
2. ALL SIGN POSTS SHALL COMPLY WITH NCHRP 350.
3. ALL POSTS SHALL BE EMBEDDED A MINIMUM OF 42".
4. BRACING OF POST IS NOT PERMITTED.
5. SIGN SHALL BE LEVEL, AND UPRIGHT FOR THE DURATION OF INSTALLATION.
6. ERECT POSTS SO THE SIGN FACE AND SUPPORTS DO NOT VARY FROM PLUMB BY MORE THAN 3/16" IN 3'. PROVIDE A CENTER-TO-CENTER DISTANCE BETWEEN POSTS WITHIN 2 PERCENT OF PLAN DISTANCE.
7. NO MORE THAN ONE SPLICE PER POST, AS SHOWN, WILL BE PERMITTED.
8. POST TYPES SHALL NOT BE MIXED WITHIN A SIGN SUPPORT INSTALLATION.
9. NO VERTICAL JOINTS ARE PERMITTED IN SIGN. NO HORIZONTAL JOINTS THROUGH SIGN LEGEND OR SYMBOLS ARE PERMITTED IN SIGN
10. REMOVE SIGN POSTS AND/OR POST STUBS IN THEIR ENTIRETY WHEN NO LONGER REQUIRED.
11. ALL LABOR, MATERIALS, AND EQUIPMENT, INCLUDING TEMPORARY SUPPORTS REQUIRED TO INSTALL, MAINTAIN, RELOCATE, AND/OR REMOVE THE TEMPORARY SIGN, INCLUDING SUPPORTS, ARE CONSIDERED TO BE INCLUDED IN THE COST OF THE TEMPORARY SIGN.
12. SAW CUTS IN WOOD POSTS ARE TO BE PARALLEL TO THE BOTTOM OF THE SIGN.
13. POSTS SHALL NOT EXTEND MORE THAN 4" ABOVE TOP OF SIGN.
14. TEMPORARY WOOD SUPPORTS DO NOT REQUIRE PRESERVATIVE TREATMENT.

NOT TO SCALE

MICHIGAN DEPARTMENT OF TRANSPORTATION BUREAU OF DEVELOPMENT STANDARD PLAN	F.H.W.A. APPROVAL	11/2/2017 PLAN DATE	WZD-100-A	SHEET 11 OF 11
--	-------------------	------------------------	-----------	-------------------

NOTE: THE ORIGINAL SIGNED COPY IS KEPT ON FILE AT THE MICHIGAN DEPARTMENT OF TRANSPORTATION.

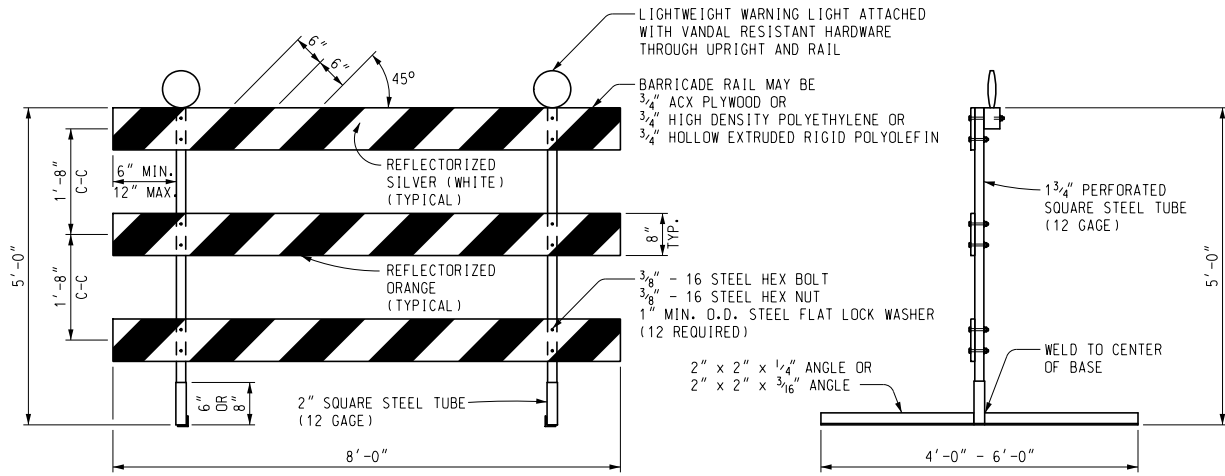

FRONT ELEVATION SIDE VIEW
PERFORATED SQUARE STEEL TUBE OPTION

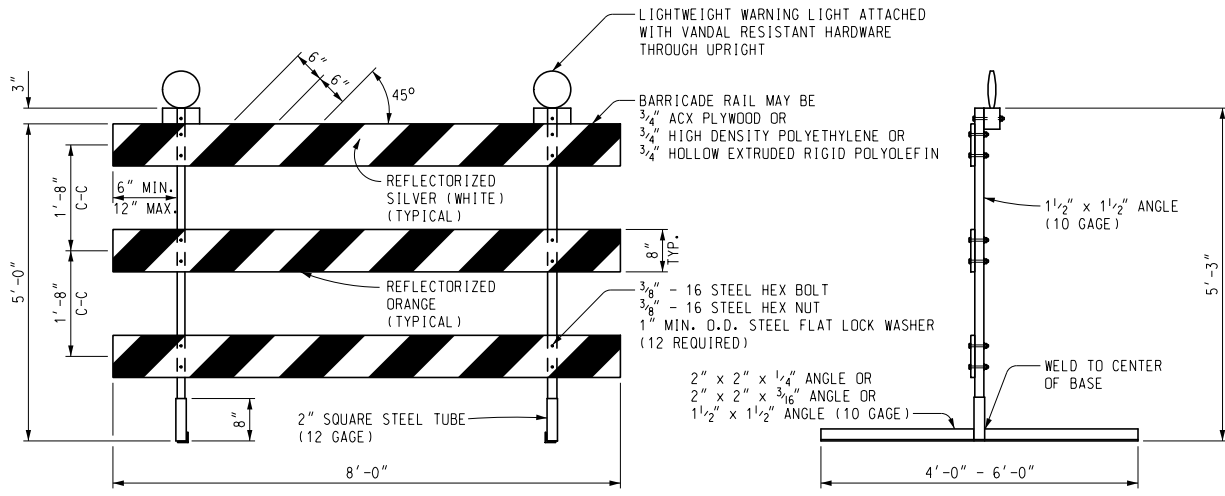

FRONT ELEVATION SIDE VIEW
ANGLE IRON OPTION

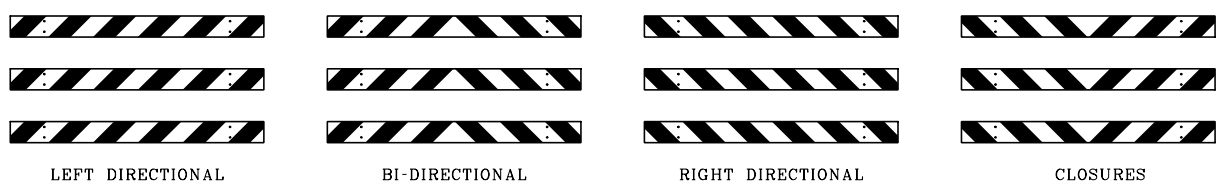

**BARRICADE RAIL SHEETING OPTIONS
 TYPE III BARRICADES**

Other Type III Barricades meeting current NCHRP crash worthy criteria can be found on the FHWA Safety website at http://safety.fhwa.dot.gov/roadway_dept/road_hardware/wzd.htm

MDOT
 Michigan Department of Transportation

PREPARED BY
 OPERATIONS
 FIELD SERVICES

DRAWN BY: ECH

CHECKED BY: MWB

DEPARTMENT DIRECTOR
 Paul C. Ajegba

APPROVED BY: _____
 DIRECTOR, BUREAU OF FIELD SERVICES

APPROVED BY: _____
 (SPECIAL DETAIL)
 DIRECTOR, BUREAU OF HIGHWAY DEVELOPMENT

MICHIGAN DEPARTMENT OF TRANSPORTATION
 BUREAU OF FIELD SERVICES SPECIAL DETAIL FOR

Temporary
 Traffic Control Devices

6/16/22
 PLAN DATE

WZD-125-E

SHEET 1 OF 3

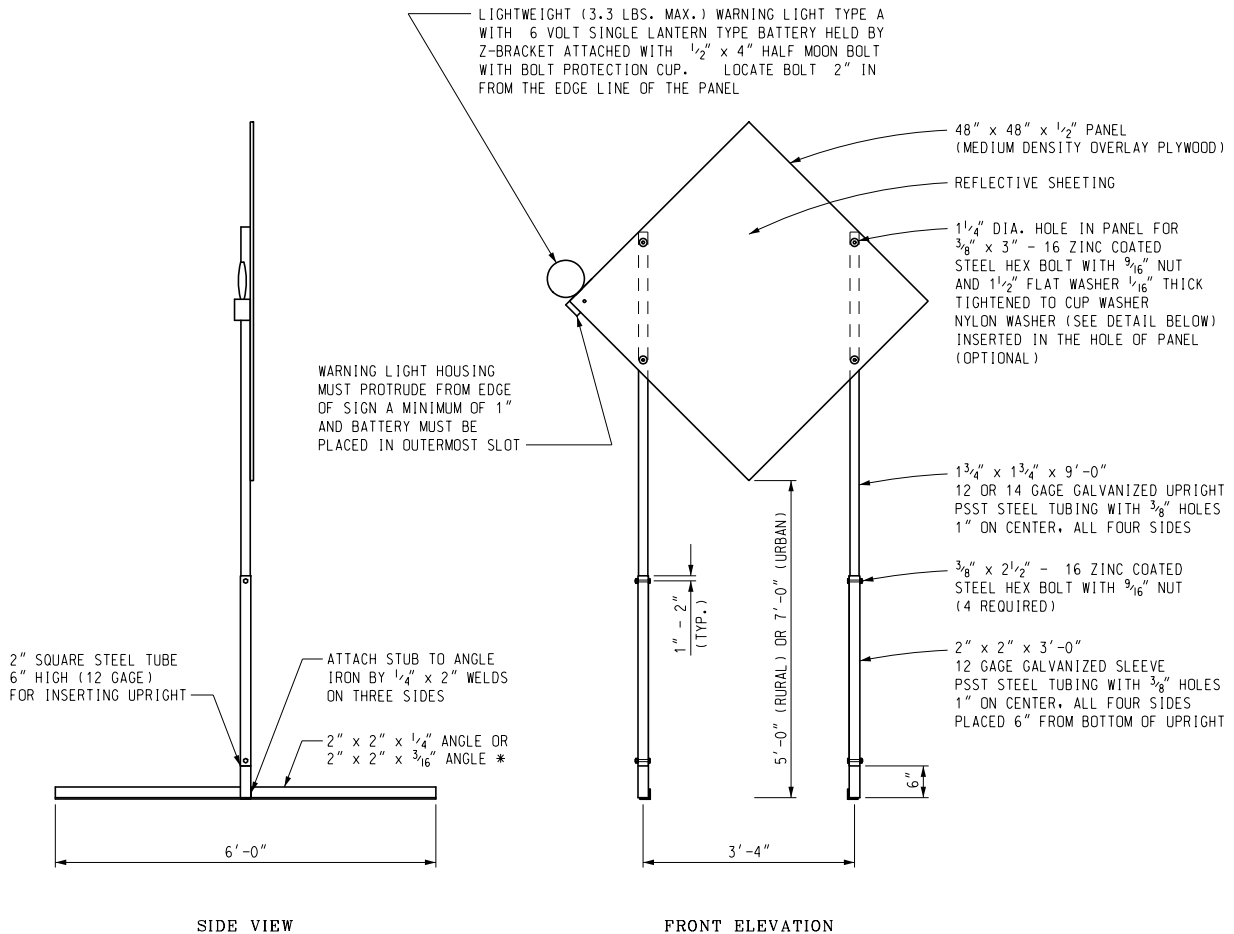

TEMPORARY SIGN SUPPORT

(WARNING LIGHT PLACED ON SIDE CLOSEST TO TRAFFIC)

* SIGN STAND IS BALLASTED WITH FOUR OR MORE 35 LB SANDBAGS. A MINIMUM OF ONE ON EACH END. UPRIGHTS SHALL NOT EXTEND ABOVE THE SIGN PANEL.

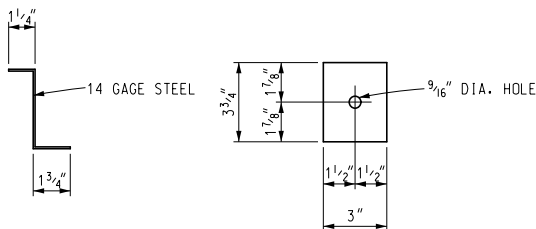

Z-BRACKET DETAIL

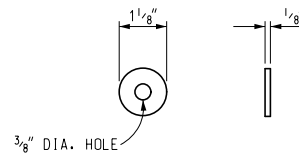

OPTIONAL NYLON WASHER

Other temporary sign supports meeting current NCHRP crash worthy criteria can be found on the FHWA Safety website at http://safety.fhwa.dot.gov/roadway_dept/road_hardware/wzd.htm

NOT TO SCALE

MICHIGAN DEPARTMENT OF TRANSPORTATION
BUREAU OF FIELD SERVICES SPECIAL DETAIL

SPECIAL DETAIL
F.H.W.A. APPROVAL

6/16/22
PLAN DATE

WZD-125-E

SHEET
2 OF 3

NOTE: THE ORIGINAL SIGNED COPY IS KEPT ON FILE AT THE MICHIGAN DEPARTMENT OF TRANSPORTATION.

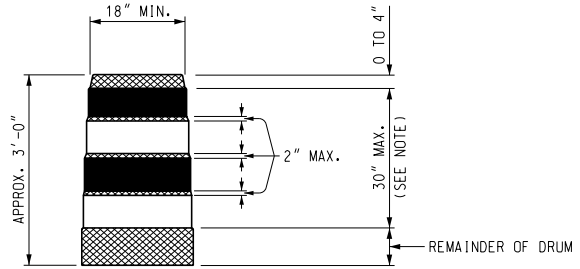

- REFLECTORIZED ORANGE
- REFLECTORIZED WHITE
- NON REFLECTORIZED ORANGE

NOTE:
 DRUMS SHALL HAVE AT LEAST 4 HORIZONTAL REFLECTORIZED STRIPES (2 ORANGE AND 2 WHITE) OF 6" UNIFORM WIDTH, ALTERNATING IN COLOR WITH THE TOPMOST REFLECTORIZED STRIPE BEING ORANGE. NON REFLECTORIZED SPACES BETWEEN THE HORIZONTAL REFLECTORIZED ORANGE AND WHITE STRIPES SHALL BE ORANGE IN COLOR AND EQUAL IN WIDTH.

PLASTIC DRUM

NOTES:

2" PERFORATED SQUARE STEEL TUBES MAY BE USED TO FABRICATE THE HORIZONTAL BASE OF THE TYPE III BARRICADE.

WARNING LIGHTS SHALL BE PLACED ACCORDING TO THE CURRENT STANDARD SPECIFICATIONS FOR CONSTRUCTION AND ALL OTHER PROVISIONS IN THE CONTRACT ON TYPE III BARRICADES.

SEE ROAD STANDARD PLANS R-113-SERIES FOR TEMPORARY CROSSOVERS FOR DIVIDED ROADWAY, AND R-126-SERIES FOR TYPICAL LOCATION AND SPACING OF PLASTIC DRUMS FOR PLACEMENT OF TEMPORARY CONCRETE BARRIER.

SIGNS, BARRICADES, AND PLASTIC DRUMS SHALL BE FACED WITH PRESSURE-SENSITIVE REFLECTIVE SHEETING ACCORDING TO THE CURRENT STANDARD SPECIFICATIONS FOR CONSTRUCTION.

SANDBAGS SHALL BE USED WHEN SUPPLEMENTAL WEIGHTS ARE REQUIRED TO ACHIEVE STABILITY OF THE BARRICADE. THE SANDBAGS SHALL BE PLACED SO THEY WILL NOT COVER OR OBSTRUCT ANY REFLECTIVE PORTION OF THE TRAFFIC CONTROL DEVICE.

NOT TO SCALE

MICHIGAN DEPARTMENT OF TRANSPORTATION
 BUREAU OF FIELD SERVICES SPECIAL DETAIL

(SPECIAL DETAIL)
 F.H.W.A. APPROVAL

6/16/22
 PLAN DATE

WZD-125-E

SHEET
 3 OF 3

NOTE: THE ORIGINAL SIGNED COPY IS KEPT ON FILE AT THE MICHIGAN DEPARTMENT OF TRANSPORTATION.

MICHIGAN
DEPARTMENT OF TRANSPORTATION

SPECIAL PROVISION
FOR
SLOPE RESTORATION, FREEWAY

RSD:NJM

1 of 3

APPR:DMG:KJK:08-19-25

a. Description. This work consists of preparing all areas designated for slope restoration on the plans or as directed by the Engineer and applying topsoil, fertilizer, seed, mulch with mulch anchor, mulch blanket, high velocity mulch blanket, permanent turf reinforcement mat, bonded fiber matrix, or modified mulch blanket to those areas. Ensure turf establishment is in accordance with section 816 and 917 of the Standard Specifications for Construction and Standard Plan R-100 Series, except as modified herein or otherwise directed by the Engineer.

b. Materials. The materials, application rates, and construction methods specified in sections 816 and 917 of the Standard Specifications for Construction apply unless modified by this special provision or otherwise directed by the Engineer. Furnish the following materials on this project:

1. Seeding mixture as called for on the plans.
2. Chemical fertilizer nutrient, Class B.
3. Topsoil. The following percentages of furnished and salvaged topsoil are estimated for this project and provided for informational purposes only.

Topsoil Furnished: 10 percent

Topsoil Salvaged: 90 percent

4. Mulching materials.
5. Modified Mulch Blanket. Where modified mulch blanket is required, furnish an excelsior mulch blanket free of chemical additives. Ensure the netting thread is 100 percent biodegradable and manufactured with non-plastic materials such as jute, sisal, or coir fiber. Degradable, photodegradable, UV-degradable, oxo-degradable, or oxo-biodegradable plastic netting including polypropylene, nylon, polyethylene, and polyester is not an acceptable alternative. All netting materials must have a loose weave design with movable junctions between the machine and cross-machine direction twines that move independently and reduce the potential for wildlife entanglement.

For Slope Restoration, Freeway, Type F, furnish a single net modified mulch blanket from the list below or an approved equal.

Premier Straw Single Net FibreNet	American Excelsior Co.	(800) 777-7645
Curlex NetFree 100% Biodegradable	American Excelsior Co.	(800) 777-7645
ECS-1B Biodegradable Single Straw	East Coast Erosion Control	(800) 582-4005
S1000BD Single Net	Enviroscape ECM, Ltd.	(888) 550-1999
Excel SR-1 All-Natural	Western Excelsior Corp.	(866) 540-9810

S75BN

Western Excelsior Corp.

(866) 540-9810

For Slope Restoration, Freeway, Type G, furnish a double net modified mulch blanket from the list below or an approved equal.

Premier Straw Double Net FibreNet	American Excelsior Co	(800) 777-7645
Curlex II FibreNet	American Excelsior Co	(800) 777-7645
ECX-2B Double Net Biodegradable	East Coast Erosion Control	(800) 582-4005
S2000BD Double Net	Enviroscape ECM, Ltd.	(888) 550-1999
Excel R-2 All Natural	Western Excelsior Corp	(866) 540-9810
Excel SS-2 All Natural	Western Excelsior Corp.	(866) 540-9810
S150BN	Western Excelsior Corp.	(866) 540-9810

c. Construction. Ensure construction methods are in accordance with subsection 816.03 of the Standard Specifications for Construction. Begin this work as soon as possible after final grading of the areas shown on the plans for slope restoration but no later than the time limitations in accordance with subsection 208.03.B of the Standard Specifications for Construction. It may be necessary, as directed by the Engineer, to place materials by hand.

Shape, compact, and ensure all areas to be seeded are weed-free prior to placing topsoil. Place topsoil to the minimum depth of 4 inches and in accordance with the plans and standard specifications to meet proposed finished grade. If the area being restored requires more than the minimum depth of topsoil to meet finished grade, fill this additional depth using topsoil or, at the Contractor's option, embankment. Furnishing and placing this additional material is included in this item of work for slope restoration.

Ensure topsoil is weed and weed seed free and friable prior to placing seed. Remove any stones greater than 2-inches in diameter or other debris. Apply seed mixture and fertilizer to prepared soil surface at the specified rates. Incorporate seed into top 1/2-inch of topsoil.

Spread mulch at a rate of two tons per acre. If the Engineer allows dormant seeding spread mulch at a rate of 3 tons per acre. Place mulch anchoring over the mulch at a rate in accordance with subsection 816.03.F of the Standard Specifications for Construction. Place mulch blanket and high-velocity mulch blanket in accordance with subsection 816.03.G of the Standard Specifications for Construction and Standard Plan R-100 Series.

Install areas constructed with the TRM on prepared (seeded) grades as shown on the plans in accordance with the manufacturer's published installation guidelines. Anchor the top edge of the TRM in a minimum six-inch deep trench. Operation of equipment on the slope is prohibited after placement of the TRM. No credit for splices, overlaps, tucks, or wasted material will be made.

Mix the BFM and organic binders thoroughly at a rate of 40 pounds for each 100 gallons of water or as otherwise recommended by the manufacturer. Hydraulically apply the BFM slurry in successive layers, from two or more directions, to fully cover 100 percent of the soil surface. Ensure the minimum application rate is at least 3000 pounds of BFM for each acre or otherwise apply in accordance with the manufacturer's recommendations as appropriate depending on site conditions.

Do not apply BFM on saturated soil or immediately before, during or after rainfall.

Install modified mulch blanket in accordance with the manufacturer’s published guidelines and as directed by the Engineer.

If an area washes out after this work has been properly completed and approved by the Engineer, make the required corrections to prevent future washouts and replace the topsoil, fertilizer, seed, and mulch treatment. This replacement will be paid for as additional work using the applicable pay items.

If an area washes out for reasons attributable to the Contractor’s activity or failure to take proper precautions, replacement will be at no cost to the contract.

The Engineer will inspect the seeded turf to ensure it is well established, in a vigorous growing condition, contains the species called for in the seeding mixture and acceptance is in accordance with subsection 816.03.K of the Standard Specifications for Construction.

If the seeded turf is not well established at the end of the first growing season, the Contractor must reseed as detailed herein until the turf is well established and approved by the Engineer at no cost to the contract.

Provide weed control, if weeds are determined by the Engineer to cover more than 10 percent of the total area of slope restoration, in accordance with subsection 816.03.I of the Standard Specifications for Construction. Weed control will be at no additional cost to the contract.

d. Measurement and Payment. The completed work, as described, will be measured and paid for at the contract unit price using the following pay items:

Pay Item	Pay Unit
Slope Restoration, Freeway, Type ____	Square Yard

1. Place **Slope Restoration, Freeway, Type F** parallel (8 feet minimum) to the edge of the roadway, in areas that have a 1 on 3 slope or less, and in any ditch with a grade less than 1.5 percent as shown on the plans, or as directed by the Engineer. **Slope Restoration, Freeway, Type F** will be measured by area in square yards in place. **Slope Restoration, Freeway, Type F** includes installing Topsoil Surface; Fertilizer, Chemical Nutrient; seeding mixture; and single net modified Mulch Blanket.